

General Description:

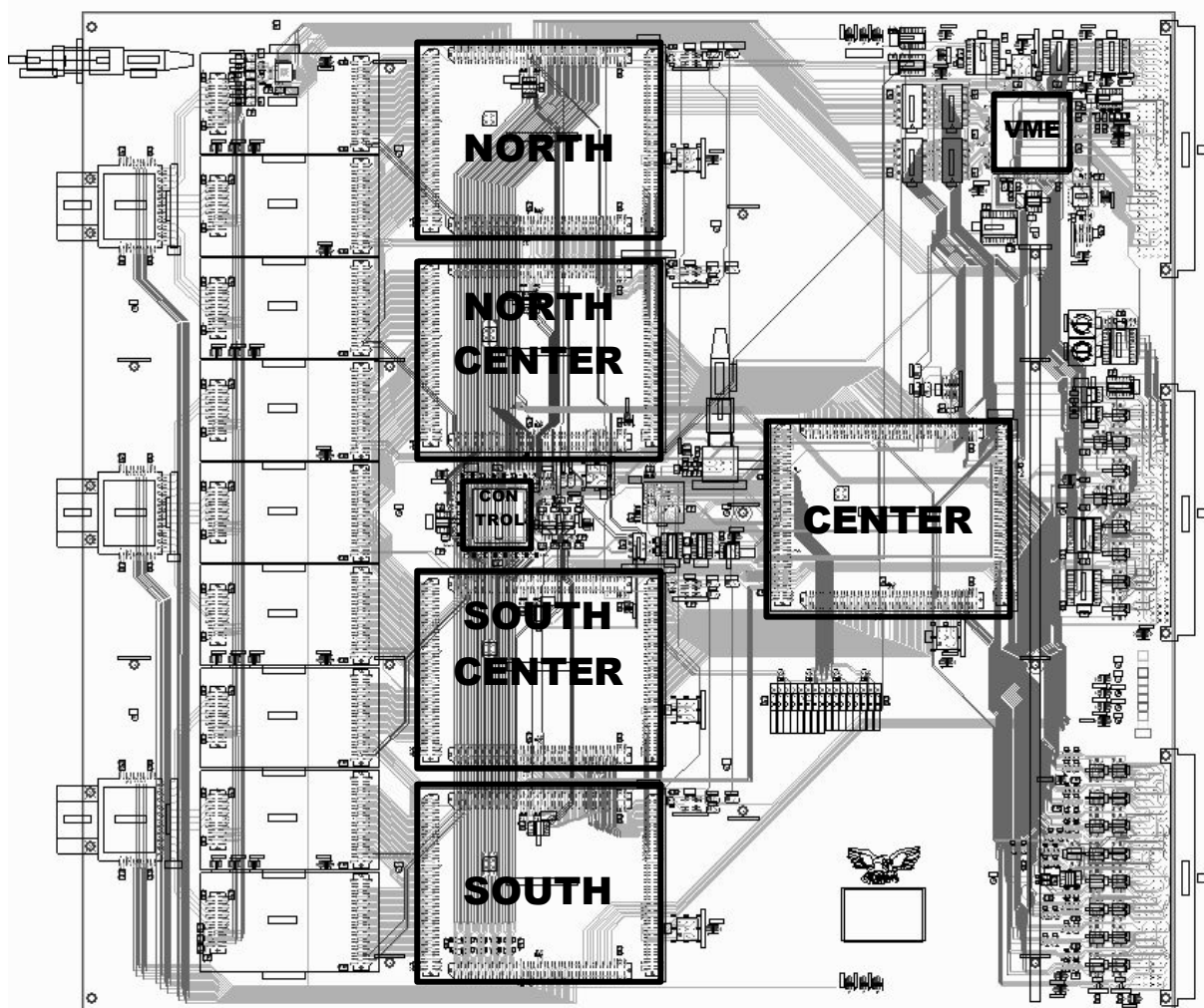

The main parts of the PixelFed are the front FPGAs called “ **NORTH** “, “ **NORTH-CENTER** ”, “ **SOUTH-CENTER** ”, “ **SOUTH** ” housing the logic functionality for the decoding state machines, with FIFO I plus FIFO II buffers and the “ **CENTER** “ FPGA containing the final FIFO III and the S-Link connection.

An additional “ **CONTROL** “ CPLD for signal distribution and a “ **VME** “ FPGA for system connection complete the module.

PREFACE

We tried to design as simple and compact as possible to increase system reliability and to facilitate maintenance work.

“ VME “ FPGA LocalBus Connection:

Two interfaces for supporting the front FPGAs and the center FPGA are foreseen. Each with 32 Address/Data lines and four Control lines, all Clock synchronized.

Address spaces:

A23	A22	A21		
0	0	0	N ALTERA	
0	0	1	NC ALTERA	LOCALBUS_FRONT
0	1	0	SC ALTERA	
0	1	1	S ALTERA	
1	1	1	BROADCAST	
1	0	0	C ALTERA	LOCALBUS_CENTER
1	0	1	VME ALTERA (internal)	

LocalBusTiming:

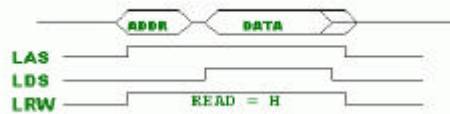

The fourth Control line **LRW**: 100ns clock synchronized pulse

VME – LocalBus address matching:

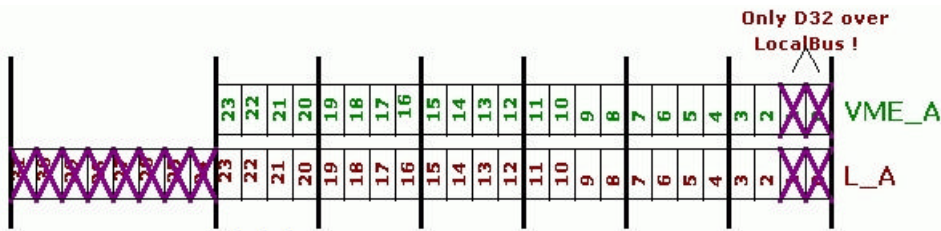

Only A32 / D32 addressing is supported in either Single- or Block- Transfer mode !

“ VME “ FPGA TTCrx Reset:

RES_TTCrx (FEDBASE+0xa00038)

A write cycle to this address triggers an external MonoFlop which generates a 50us reset pulse for the TTCrx chip. Since the VME Altera needs the TTCrx Clock it is necessary that the next VME access has to have a minimum delay of 100us. In practice, the TTCrx clock may take longer to recover. A 1ms minimum wait is recommended after a TTCrx reset.

“ VME “ FPGA JTAG Busses:

It is possible to program all ALTERA EEPROMs (of course except the one of the VME ALTERA) on the board over the VME Interface.

This is done with two independent JTAG Buses.

JTAG chain 1 : “ **NORTH** “
 “ **NORTH-CENTER** “
 “ **SOUTH-CENTER** “
 “ **SOUTH** “

JTAG chain 2 : “ **CENTER** “
 “ **CONTROL** “

The VME Addresses are as follows:

<p>JTAG1_WRITE (FEDBASE+0xa00018) D[1] TMS D[2] TDI</p>	<p>JTAG2_WRITE (FEDBASE+0xa0001c) D[1] TMS D[2] TDI</p>
<p>JTAG_1or2_READ (FEDBASE+0xa00020) read with TDI=0 and TMS=0 (FEDBASE+0xa00024) read with TDI=0 and TMS=1 (FEDBASE+0xa00028) read with TDI=1 and TMS=0 (FEDBASE+0xa0002c) read with TDI=1 and TMS=1</p>	
<p>Data read: D[7] TDO</p>	

Jam Byte Code files are used with an adapted “JAM BYTE CODE PLAYER” from ALTERA.

Attention: The original ALTERA Software Version 2.1 doesn't support EPC8 EEPROMs so please use Version 2.2

Reprogramming an ALTERA EEPROM doesn't immediately change the FPGAs behaviour. You have to invoke a configuration cycle, this is done either by POWER off/on or with the VME registered command:

nCONFIG (FEDBASE+0xa00018)
D[0] = 1 nCONFIG = Low (due to external inverter)
D[0] = 0 nCONFIG = High

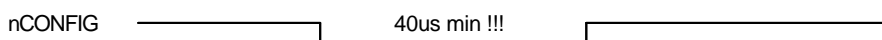

On V5 modules we have two separate configuration lines, one for the **front** chips (served by **D[0]**) and one for the **center** chips (served by **D[1]**).

The reason for this modification was to ensure that varying configuration times have no influence on the module startup behavior.

“ VME “ FPGA I2C MASTER :

The simple I2C Master implemented as a VHDL State machine is capable of writing and reading up to four Bytes. “Bus Busy” and “I2C Acknowledge” Errors are reported. Repeated Start is not supported !

In the PXLFEED it provides an I2C interface to the TTCrx Chip.

VME Addresses:

I2C_RES (FEDBASE+0xa00008)
Reset for the I2C State Machine

I2C_LOAD (FEDBASE+0xa0000c)
Payload :
D[7..0] Byte 1
D[15..8] Byte2
D[23..16] Byte3
D[31..24] Byte4

I2C_ADDR_RW (FEDBASE+0xa00010)
Address :
D[0] 1 = R 0 = W
D[7..1] I2C Addr.
D[9..8] Number of Bytes

I2C_RD_DATA (FEDBASE+0xa00010)
Read :
D[7..0] Byte 1
D[15..8] Byte2
D[23..16] Byte3
D[31..24] Byte4

I2C_RD_STAT (FEDBASE+0xa00014)
Error Register:
Bit 0 = 1 Bus Busy Error
Bit 1 = 1 AddrAck Error
Bit 2 = 1 WByteAck Error
Bit 3 = 1 LastByteAck Error

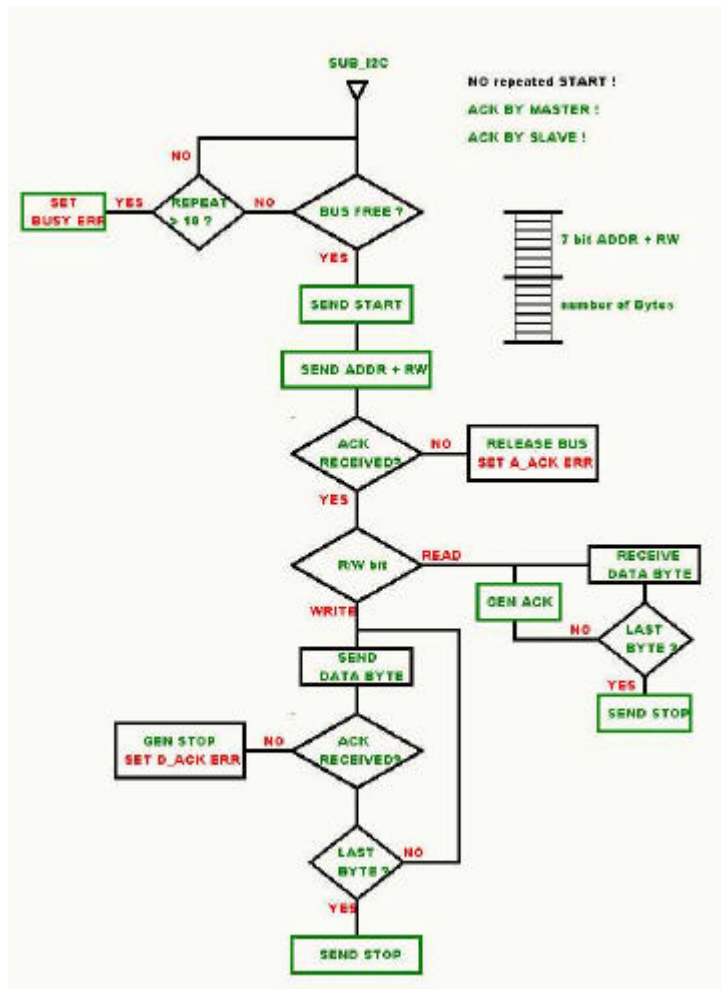

Wait cycles have to be included before Status Register can be read because of the slow I2C Clock. (I2C SCL is adjusted to 40Mhz / 256 = 156.25kHz)

Schematic Details:

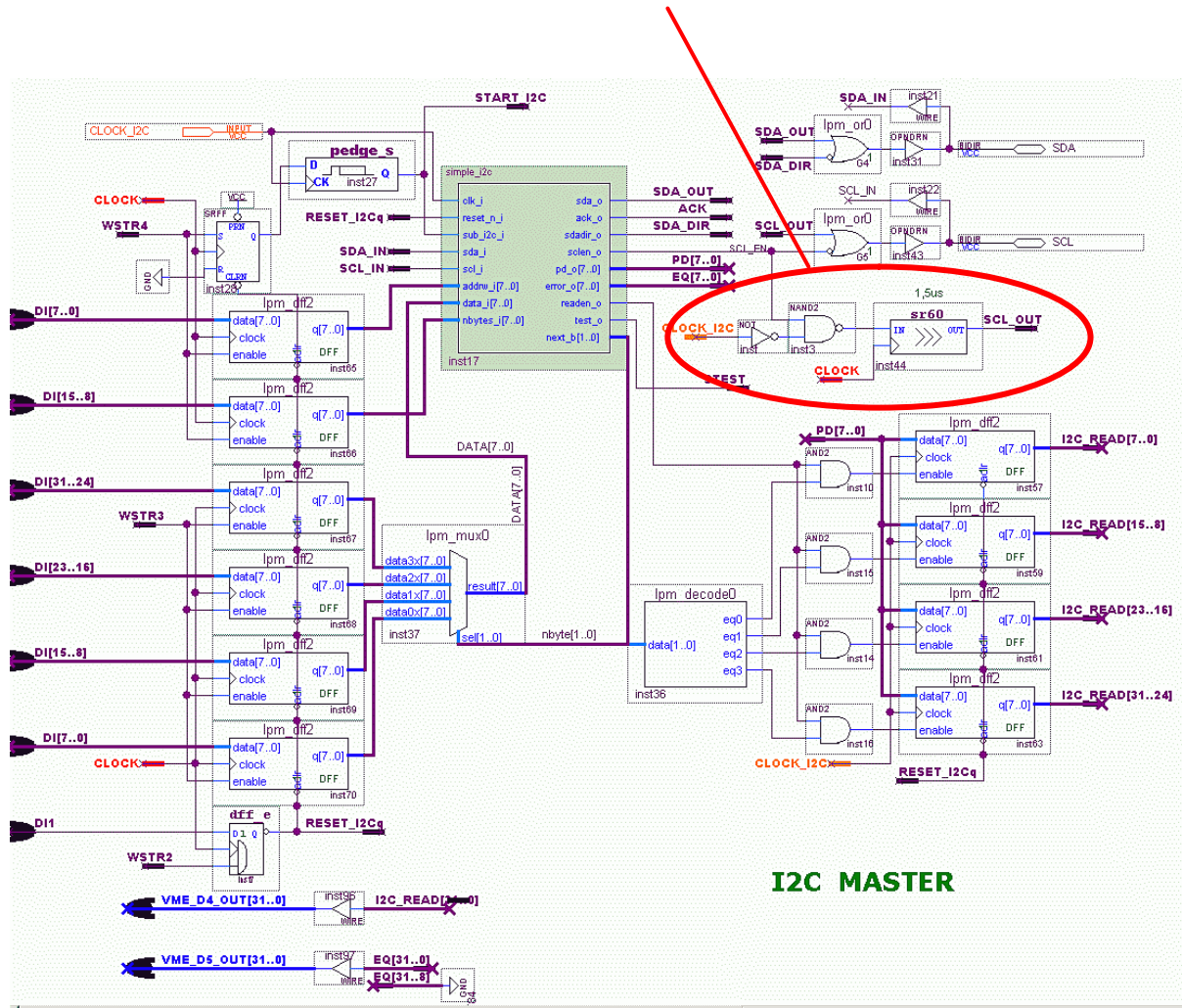
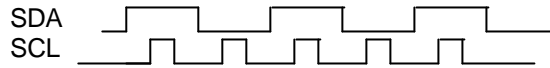

STATE MACHINE DETAIL:

```

p_get_SDA: process (clk_i, reset_n_i)
begin
    if (reset_n_i = '0') then s_sda_response <= '1';
    elsif clk_i'EVENT AND (clk_i = '0') then
        if (s_sddir = '0' AND sda_i = '0') then s_sda_response <= '0';
        else s_sda_response <= '1';
        end if;
    end if;
    ack_o <= s_sda_response;
end process p_get_SDA;

```

SDA is monitored on negative edge to have time enough for acknowledge decision.

“ FRONT “ FPGAs

Data Path Block Diagram :

CLOCK PHASE Selection

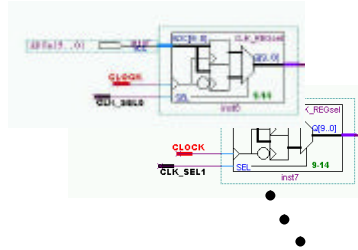

DECODING FSMs

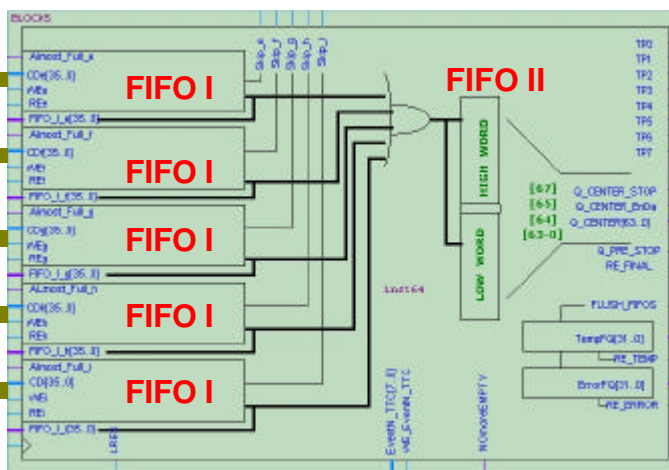
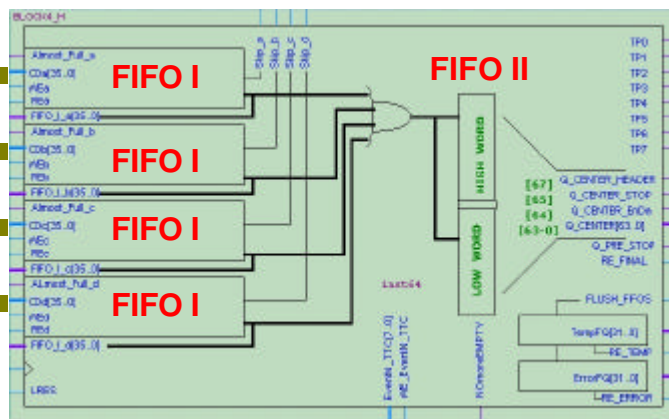

to CENTER FIFO III

“ FRONT “ FPGAs Decoding FSM :

The encoding of the ADC Data is done by a State Machine written in VHDL. Necessary multipliers are implemented as ALTERA library blocks to ensure proper synthesise results.

STATE DIAGRAM:

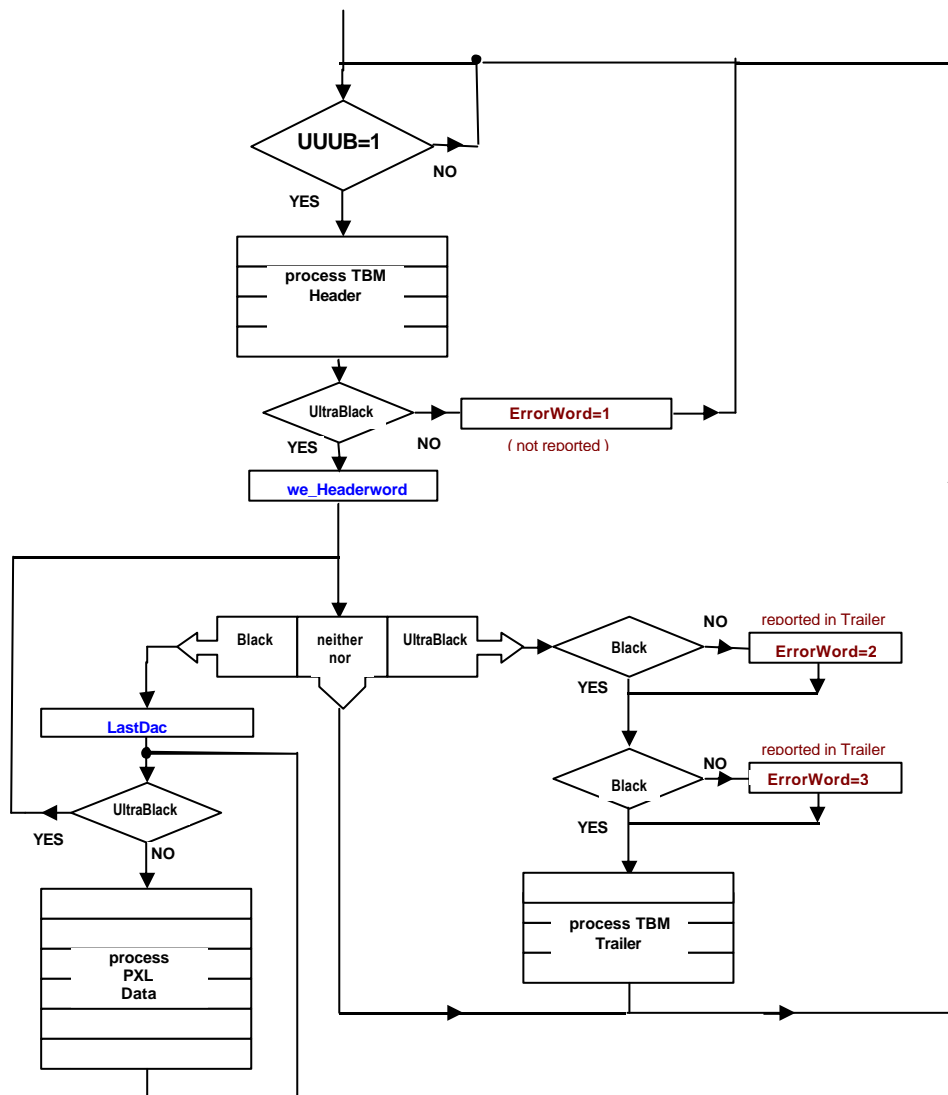

Decoding FSM output data format “normal mode”:

```

BitPos: 35 34 33 32 | 31 30 29 28 27 26 | 25 24 23 22 21 | 20 19 18 17 16 15 14 13 12 11 10 09 08 | 07 06 05 04 03 02 01 00 |
Header: 1 0 0 0 | < -CHANNEL #-- > | 1 1 1 1 1 | 0 ----- 0 | < --TBM HEADER TRG#-- > |
          0x8 | | 0x1f (31) | | |
          HeaderID | | Header Marker | | |
  
```

```

BitPos: 35 34 33 32 | 31 30 29 28 27 26 | 25 24 23 22 21 | 20 19 18 17 16 15 14 13 12 11 10 09 08 | 07 06 05 04 03 02 01 00 |
LastDac: 1 1 0 0 | < -CHANNEL #-- > | < --ROC #-- > | 0 ----- 0 | < ---- LAST DAC ---- > |
          0xc | | | | |
          LastDacID | | | | |
  
```

```

BitPos: 35 34 33 32 | 31 30 29 28 27 26 | 25 24 23 22 21 | 20 19 18 17 16 | 15 14 13 12 11 10 09 08 | 07 06 05 04 03 02 01 00 |
Data: 0 0 0 1 | < -CHANNEL #-- > | < --ROC #-- > | < --DCOL -- > | < ----- Pxl ----- > | < ----PulseHeight---- > |
          0x1 | | | | |
          DataID | | | | |
  
```

```

BitPos: 35 34 33 32 | 31 30 29 28 27 26 | 25 24 23 22 21 | 20 19 18 17 16 15 14 13 12 11 10 09 08 | 07 06 05 04 03 02 01 00 |
Trailer: 0 1 0 0 | < -CHANNEL #-- > | 1 1 1 1 0 | 0 ----- 0 e2 e1 e0 0 | < --TBM Trailerword-- > |
          0x4 | | 0x1c (30) | | e2 | => invalid number of ROCs |
          TrailerID | | Trailer Marker | | e1 e0 | => FSM ErrorByte |
  
```

An Error-Trailer is generated if there are more than 192 Pixels / Channel :

```

BitPos: 35 34 33 32 | 31 30 29 28 27 26 | 25 24 23 22 21 | 20 19 18 17 16 15 14 13 12 11 10 09 08 | 07 06 05 04 03 02 01 00 |
ErrTrl: 0 1 0 0 | < -CHANNEL #-- > | 1 1 1 1 0 | 0 ----- 0 e2 e1 e0 1 | 0 ----- 0 |
          0x4 | | 0x1e (30) | | | |
          TrailerID | | Trailer Marker | | | |
  
```

When the Decoding Machine detects an “Almost Full” from FIFO I then only “HEADER”, “LASTDAC” and “TRAILER” words are produced.

Decoding FSM output data format “transparent mode”:

In “transparent mode” a block of 512 ADC Data , starting with a trigger Signal from the Center chip, is stored in FIFO I

ADC Data:

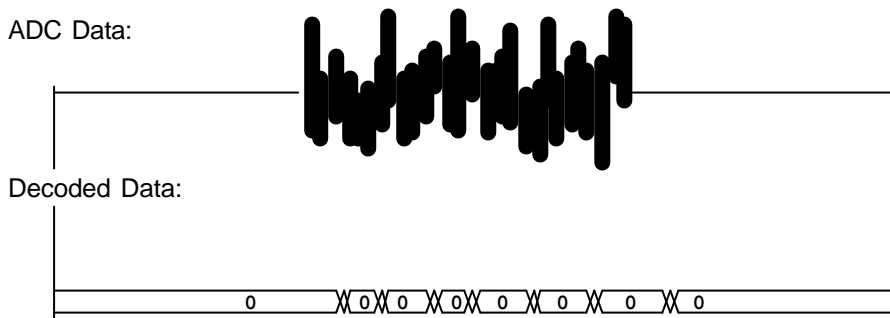

When Pixel decoding is finished, the result is stored in Bits 21..0 , otherwise these Bits are 0!

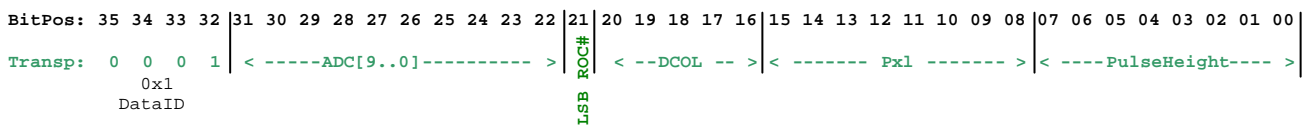

The 513th Data in transparent mode is marked with 0xff in Bits 7..0 !

RESET possibilities:

Each Local Bus has its own Reset line called LRES and CLRES.

LRES (FEDBASE+0xa00000) **D[31]=1** **CLRES** (FEDBASE+0xa00004) **D[31]=1**

Write Cycles to this addresses with D[31]=1 generate 100ns reset pulses common to the Front Alteras (LRES) or the Center Altera (CLRES).

LRES resets the PixelStateMachine, clears all pipeline registers and flushes FIFO I, FIFO II, ErrorFIFO, and TemperatureFIFO.

CLRES flushes the HEADER FIFO and FIFO III.

One can selectively reset the Phase Locked Loop (PLL) on the front AlteraFPGA's with the following

LRES (FEDBASE+0x1c8000) **D[29]=1**

This LocalBus Address is used for special reset possibilities:

BROADCAST or CHP_ADDR + 0x1c8000 D[31..0]

Previously only D[31] was used in the FrontAlteras for flushing all SpyFIFOs and in the NORTH Chip for resetting the Test DAC RAMCounter.

Pixel B-channel Commands:

BRCST[5..0] = 0x2 (= reset EventCounter)
BRCST[5..0] = 0x14 (= FullReset)

FullReset is distributed to the Front ALTERAs and has the same effect as sending LRES and CLRES !

OPTO-RECEIVER parameters:

The parameters for the opto receivers can be set as follows:

LocalBus Addr:

LAD_S + 0x180000	OPTOPAR RECEIVER1 D[7..0]	Channels 1 to 12
LAD_S + 0x188000	OPTOPAR RECEIVER2 D[7..0]	Channels 13 to 24
LAD_S + 0x190000	OPTOPAR RECEIVER3 D[7..0]	Channels 25 to 36

Data word :

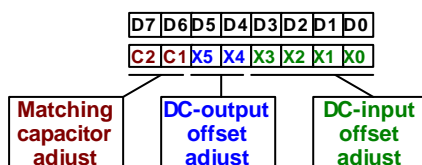

Setting thresholds for the 6 discrete levels :



One have to set threshold levels for every ROC on all channels.

Address space:

```

UB_B_THRESH : A[20..17]=Channel_Addr:   A[16..14]=2   common for all ROCs !
L012_THRESH : A[20..17]=Channel_Addr:   A[16..14]=4   A[6..2]=ROC Address
UB_B_THRESH : A[20..17]=Channel_Addr:   A[16..14]=5   A[6..2]=ROC Address
    
```

Data words:

```

BitPos: 31 30 | 29 28 27 26 25 24 23 22 21 20 | 19 18 17 16 15 14 13 12 11 10 | 09 08 07 06 05 04 03 02 01 00 |
UB_B_THRESH | < ---- BH ----- > | < ----- BL ----- > | < ----- UB ----- >
    
```

```

BitPos: 31 30 | 29 28 27 26 25 24 23 22 21 20 | 19 18 17 16 15 14 13 12 11 10 | 09 08 07 06 05 04 03 02 01 00 |
L012       | < -----LEVEL 2 ----- > | < ----- LEVEL 1 ----- > | < ----- LEVEL 0 ----- >
    
```

```

BitPos: 31 30 29 28 27 26 25 24 23 22 21 20 | 19 18 17 16 15 14 13 12 11 10 | 09 08 07 06 05 04 03 02 01 00 |
L34      | < ----- LEVEL 4 ----- > | < ----- LEVEL 3 ----- >
    
```

ROC numbering starts with one! ROC address zero is intended to be used for TBM HEADER levels and the address (Number of ROCs used + 1) can be used for TBM TRAILER levels since the internal ROC counter counts with each UB sequence and the maximum number of Rocs used is 24 (5bit ROC address range).

Individual channel offsets:

There are three 12 Channel DACs (AD8802) for channel offset control. The serial interface for these DACs is located in the NORTH Chip.

Address:

LAD_N + 0x190000

DataWord:

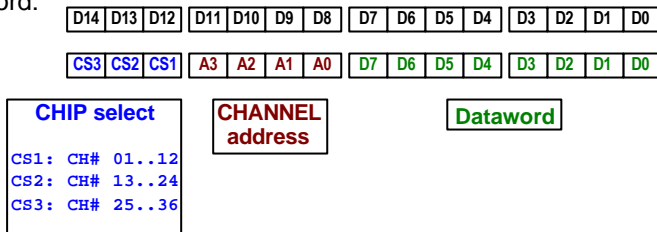

Settling time due to external decoupling capacitor aprox. 1ms !

Analog Levels:

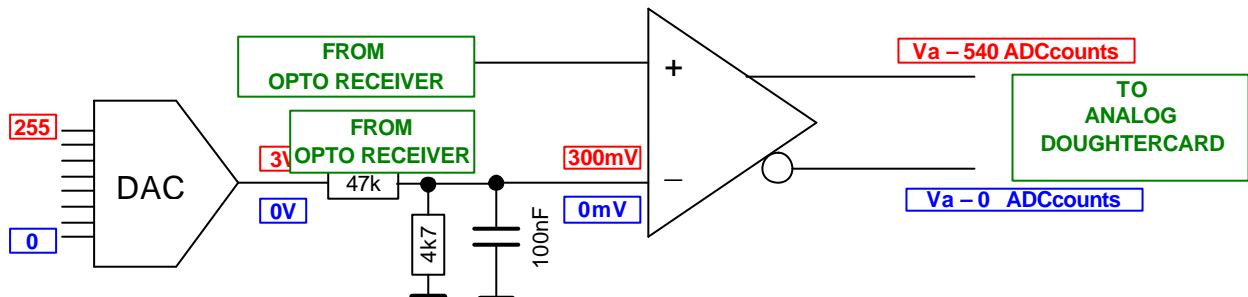

Individual channel ADC gain factor:

Each individual bit controls one ADC chip = 2 ADC channels ! I.e. Bit 0 for the North FPGA controls ADC channels 1 and 2, The ADC conversion can be changed from 1Vpp = 1024 counts (bit=0) to 2 Vpp = 1024 counts (bit=1).

Also don't forget to change the offset DAC: 0 ADC counts for 1Vpp(2Vpp) = -0.5V (-1.0V)!

Address:

LAD_N(NC,SC,S) + 0x1b8000

DataWord:

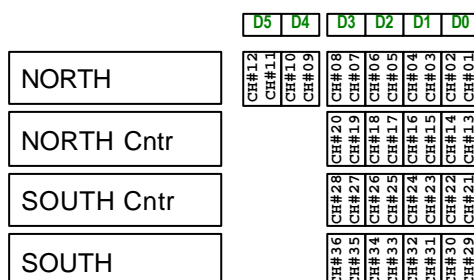

Automatic baseline correction:

If this feature is enabled the FED uses the time between TBM_TRAILER and TBM_HEADER to correct the “black level” to a programmable value by digitally adding or subtracting.

We suggest the following procedure:

- .) Disable the auto correction
- .) Add offset to get black Level approximately correct
- .) Determine UB and B levels in transparent mode (necessary to recognise header and trailer !)
- .) Program desired black level and enable auto correction
- .) Perform additional transparent run to determine the other levels

Schematic detail:

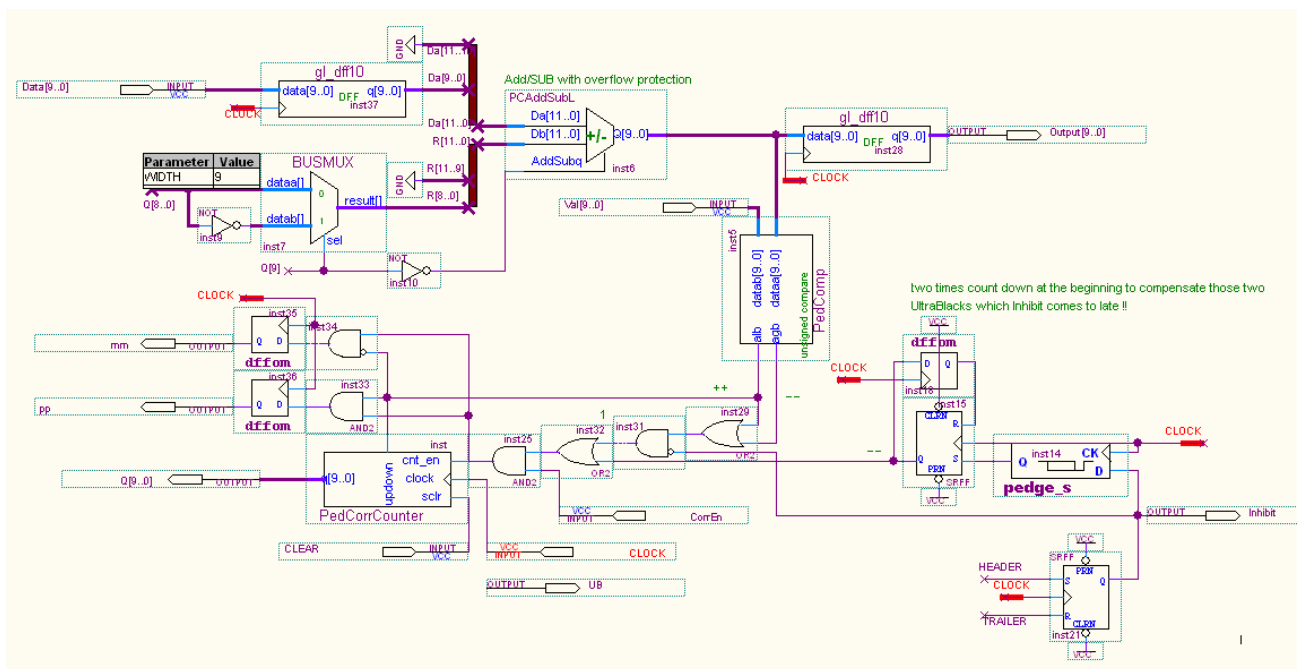

Addresses:

write:

CHP_ADDR+0x1d0000 D[24..16] enableAutoCorr CH#[9..1] D[9..0] Common value for channels 1- 9

read:

CHP_ADDR+0x1d0000 D[29..0] Correction Value CH# 3 2 1 (each 10 bit signed)

CHP_ADDR+0x1d8000 D[29..0] Correction Value CH# 6 5 4

CHP_ADDR+0x1e0000 D[29..0] Correction Value CH# 9 8 7

CLOCK PHASE ADJUSTMENT:

It is possible to adjust the ADC clock in 16 steps of about 1.5ns
 Since the ADC clock is shifted relative to the ALTERA system clock it is necessary to implement a negative edge clocked register for some delay positions to ensure proper setup and hold times for the ADC data path.

Clock phase scheme:

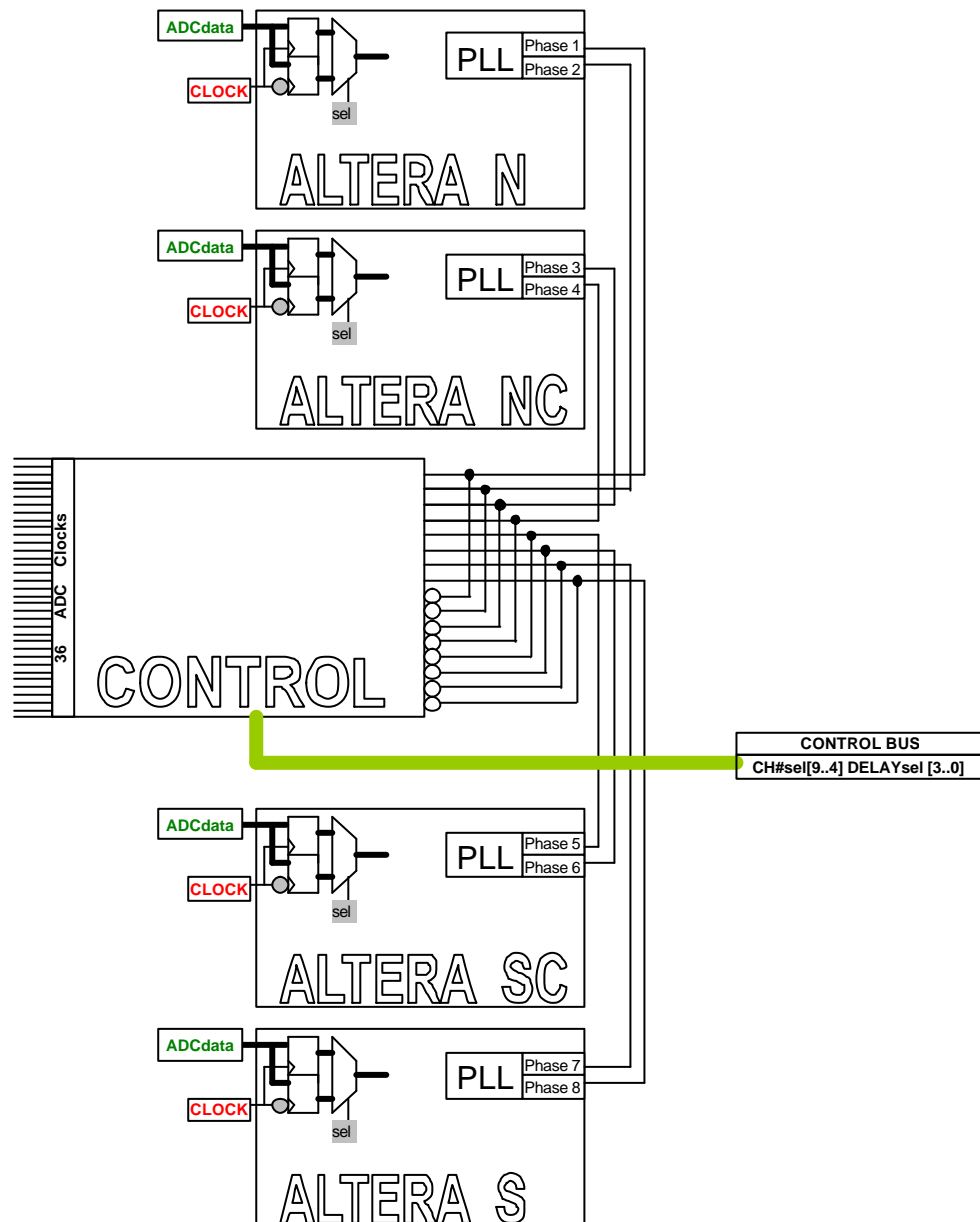

Clock phase setting is done as follows:

First: One have to set the clock phase for the selected channel.

Address:

LAD_C + 0x198000

DataWord:

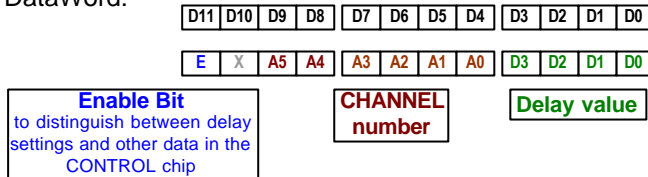

Second: Don't forget to select the appropriate clock edge for the first register in the ADC data path !

Address:

LAD_CHIPnr + 0x1b0000

DataWord:

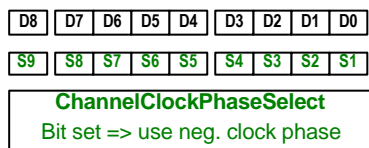

To save address space there is only one 9bit wide register for all input channels of a chip (N, NC, SC, S), therefore it is necessary to restore phase information from the other channels.

The window for positive and negative clock phase depends on the phase relationship between system clock and delayed clocks.

For version 3 modules :

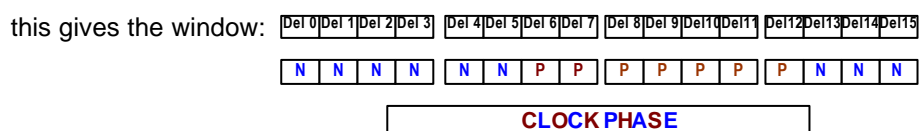
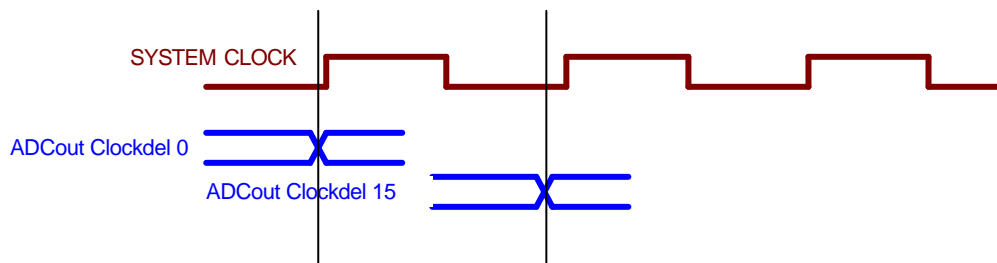

TEST DAC PULSE SCAN:

To understand the basic mechanism of clock phase adjustment, please have a look on following example.

We send sixteen times a 25ns pulse over our TEST DAC system and scan it each time with a different clock phase.

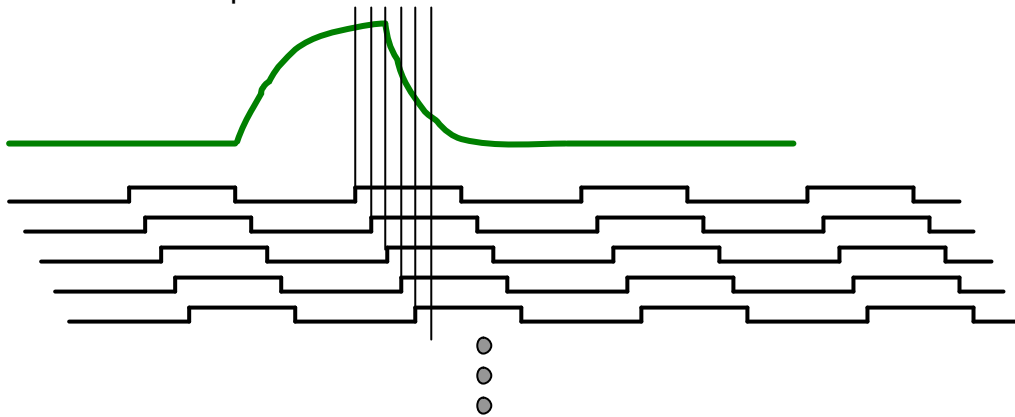

When you have found the position **n** of the pulse in FIFO I it is necessary to realign all sixteen samples to get the correct pulse shape.

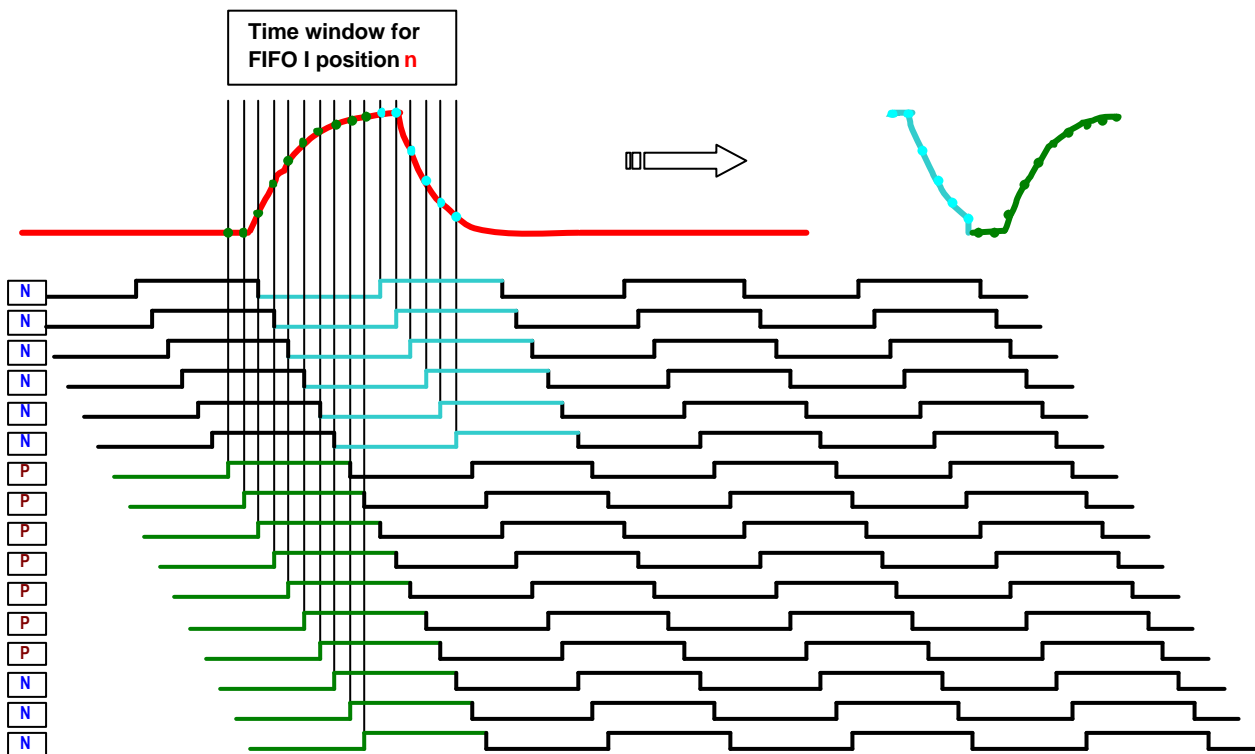

An idea how to find the best sampling point:

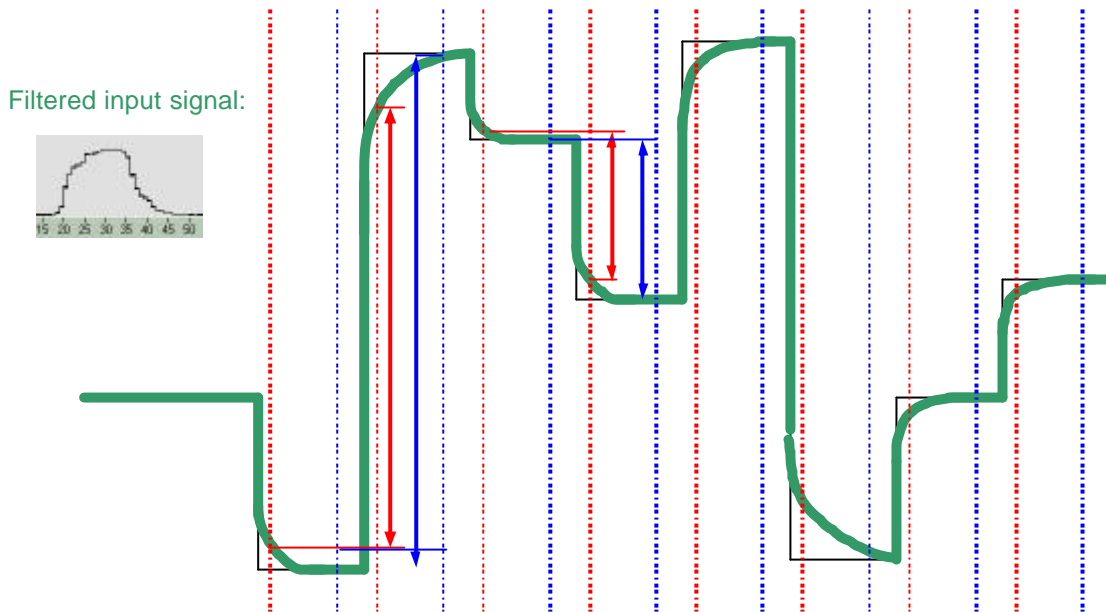

When we shift the sampling clock and build the difference of two consecutive samples, we will get a minimum when we sample at the time when the data is changing.
 In the figure above one can see that the red differences are always smaller than the blue ones.

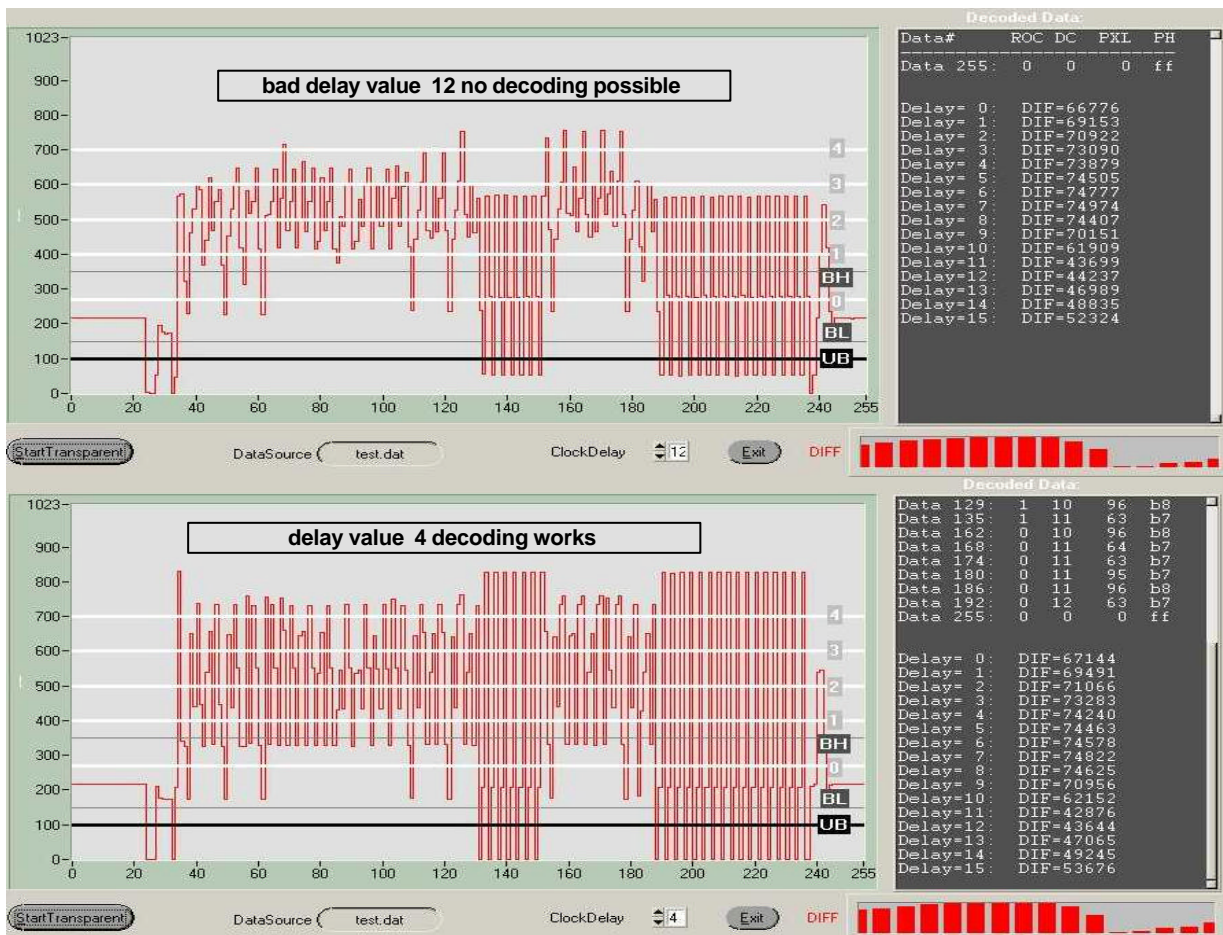

TestDAC Loading:

The built in Test system is based on the following scheme and is used for the generation of “Pixel look a like Data” to test the entire module.

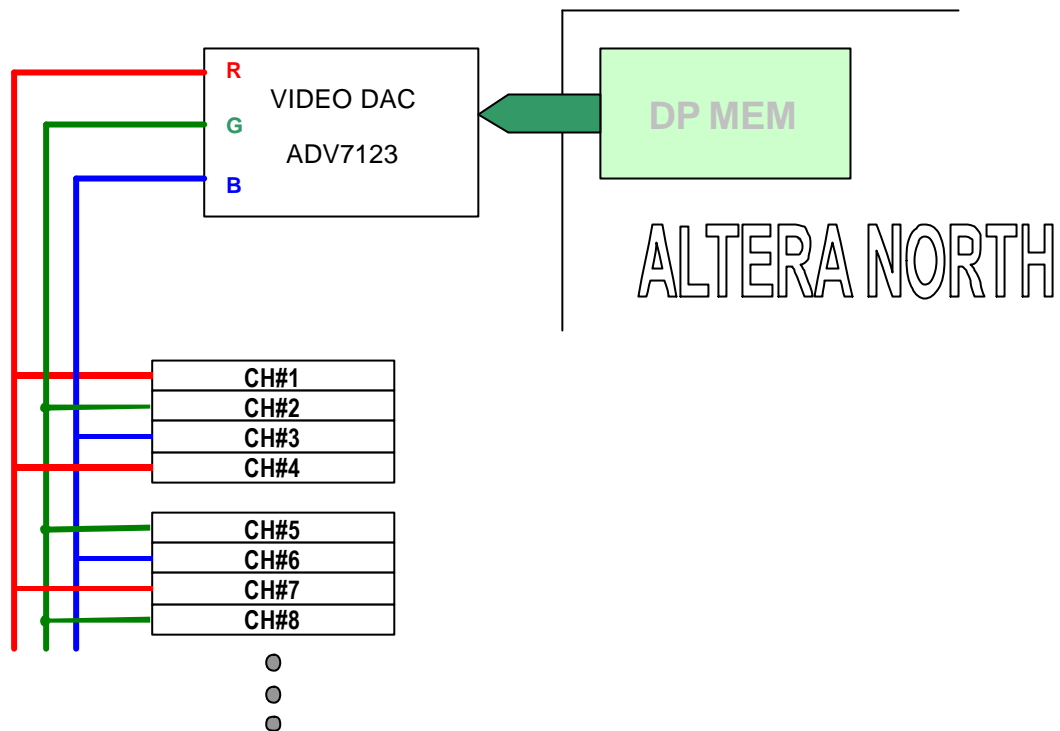

Every third channel gets the same test pattern !

Address:

LAD_N + 0x180000

DataWord:

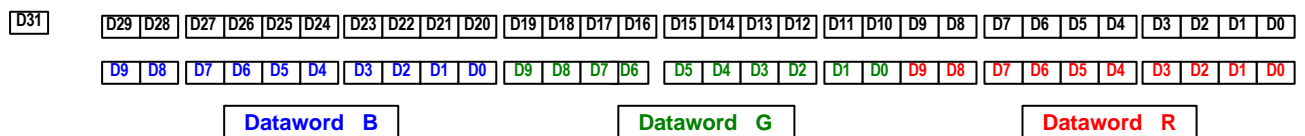

Test pattern should start at the beginning of the transparent gate, since we wait now only 64 clocks after L1A for the first header word, and should be a maximum of 256 DataWords long.

The gate can be shortened by setting bit[31] = 1 at the end of the test pattern!

NORTH_V3 LocalBus Addressmap:

		A20	A19	A18	A17	A16	A15	A14	
CHP_ADDR + 0x20000	Channel#1	0	0	0	1	0	0	0	Number of estimated ROCs D[4..0]
CHP_ADDR + 0x28000	Channel#1	0	0	0	1	0	1	0	UltraBlack Threshold D[29..0]
CHP_ADDR + 0x30000	Channel#1	0	0	0	1	1	0	0	Threshold_012 D[29..0]
CHP_ADDR + 0x34000	Channel#1	0	0	0	1	1	0	1	Threshold_34 D[19..0]
CHP_ADDR + 0x38000	Channel#1	0	0	0	1	1	1	0	READ FIFO1 D[31..0]
CHP_ADDR + 0x40000	Channel#2	0	0	1	0	0	0	0	Number of estimated ROCs D[4..0]
CHP_ADDR + 0x48000	Channel#2	0	0	1	0	0	1	0	UltraBlack Threshold D[29..0]
CHP_ADDR + 0x50000	Channel#2	0	0	1	0	1	0	0	Threshold_012 D[29..0]
CHP_ADDR + 0x54000	Channel#2	0	0	1	0	1	0	1	Threshold_34 D[19..0]
CHP_ADDR + 0x58000	Channel#2	0	0	1	0	1	1	0	READ FIFO1 D[31..0]
CHP_ADDR + 0x60000	Channel#3	0	0	1	1	0	0	0	Number of estimated ROCs D[4..0]
CHP_ADDR + 0x68000	Channel#3	0	0	1	1	0	1	0	UltraBlack Threshold D[29..0]
CHP_ADDR + 0x70000	Channel#3	0	0	1	1	1	0	0	Threshold_012 D[29..0]
CHP_ADDR + 0x74000	Channel#3	0	0	1	1	1	0	1	Threshold_34 D[19..0]
CHP_ADDR + 0x78000	Channel#3	0	0	1	1	1	1	0	READ FIFO1 D[31..0]
CHP_ADDR + 0x80000	Channel#4	0	1	0	0	0	0	0	Number of estimated ROCs D[4..0]
CHP_ADDR + 0x88000	Channel#4	0	1	0	0	0	1	0	UltraBlack Threshold D[29..0]
CHP_ADDR + 0x90000	Channel#4	0	1	0	0	1	0	0	Threshold_012 D[29..0]
CHP_ADDR + 0x94000	Channel#4	0	1	0	0	1	0	1	Threshold_34 D[19..0]
CHP_ADDR + 0x98000	Channel#4	0	1	0	0	1	1	0	READ FIFO1 D[31..0]
CHP_ADDR + 0xa0000	Channel#5	0	1	0	1	0	0	0	Number of estimated ROCs D[4..0]
CHP_ADDR + 0xa8000	Channel#5	0	1	0	1	0	1	0	UltraBlack Threshold D[29..0]
CHP_ADDR + 0xb0000	Channel#5	0	1	0	1	1	0	0	Threshold_012 D[29..0]
CHP_ADDR + 0xb4000	Channel#5	0	1	0	1	1	0	1	Threshold_34 D[19..0]
CHP_ADDR + 0xb8000	Channel#5	0	1	0	1	1	1	0	READ FIFO1 D[31..0]
CHP_ADDR + 0xc0000	Channel#6	0	1	1	0	0	0	0	Number of estimated ROCs D[4..0]
CHP_ADDR + 0xc8000	Channel#6	0	1	1	0	0	1	0	UltraBlack Threshold D[29..0]
CHP_ADDR + 0xd0000	Channel#6	0	1	1	0	1	0	0	Threshold_012 D[29..0]
CHP_ADDR + 0xd4000	Channel#6	0	1	1	0	1	0	1	Threshold_34 D[19..0]
CHP_ADDR + 0xd8000	Channel#6	0	1	1	0	1	1	0	READ FIFO1 D[31..0]
CHP_ADDR + 0xe0000	Channel#7	0	1	1	1	0	0	0	Number of estimated ROCs D[4..0]
CHP_ADDR + 0xe8000	Channel#7	0	1	1	1	0	1	0	UltraBlack Threshold D[29..0]
CHP_ADDR + 0xf0000	Channel#7	0	1	1	1	1	0	0	Threshold_012 D[29..0]
CHP_ADDR + 0xf4000	Channel#7	0	1	1	1	1	0	1	Threshold_34 D[19..0]
CHP_ADDR + 0xf8000	Channel#7	0	1	1	1	1	1	0	READ FIFO1 D[31..0]
CHP_ADDR + 0x100000	Channel#8	1	0	0	0	0	0	0	Number of estimated ROCs D[4..0]
CHP_ADDR + 0x108000	Channel#8	1	0	0	0	0	1	0	UltraBlack Threshold D[29..0]
CHP_ADDR + 0x110000	Channel#8	1	0	0	0	1	0	0	Threshold_012 D[29..0]
CHP_ADDR + 0x114000	Channel#8	1	0	0	0	1	0	1	Threshold_34 D[19..0]
CHP_ADDR + 0x118000	Channel#8	1	0	0	0	1	1	0	READ FIFO1 D[31..0]
CHP_ADDR + 0x120000	Channel#9	1	0	0	1	0	0	0	Number of estimated ROCs D[4..0]
CHP_ADDR + 0x128000	Channel#9	1	0	0	1	0	1	0	UltraBlack Threshold D[29..0]
CHP_ADDR + 0x130000	Channel#9	1	0	0	1	1	0	0	Threshold_012 D[29..0]
CHP_ADDR + 0x134000	Channel#9	1	0	0	1	1	0	1	Threshold_34 D[19..0]
CHP_ADDR + 0x138000	Channel#9	1	0	0	1	1	1	0	READ FIFO1 D[31..0]
CHP_ADDR + 0x140000		1	0	1	0	0	0		READ_ERROR_FIFOup D[31..0]
CHP_ADDR + 0x148000		1	0	1	0	0	1		READ_TEMP_FIFOup D[31..0]
CHP_ADDR + 0x150000		1	0	1	0	1	0		READ_SPY-FIFO2up D[31..0]
CHP_ADDR + 0x158000		1	0	1	0	1	1		READ_SPY-I-up D[31..0]
CHP_ADDR + 0x160000		1	0	1	1	0	0		READ_ERROR_FIFOdown D[31..0]
CHP_ADDR + 0x168000		1	0	1	1	0	1		READ_TEMP_FIFOdown D[31..0]
CHP_ADDR + 0x170000		1	0	1	1	1	0		READ_SPY-FIFO2down D[31..0]
CHP_ADDR + 0x178000		1	0	1	1	1	1		READ_SPY-I-down D[31..0]
CHP_ADDR + 0x180000		1	1	0	0	0	0		Write_DAC_MEM D[29..0]
CHP_ADDR + 0x188000		1	1	0	0	0	1		Write_Ovfl_Val. D[7..0]+192 not impl.
CHP_ADDR + 0x190000		1	1	0	0	1	0		W_OffsetDAC D15,D14,D13,D12,D[11..0]
CHP_ADDR + 0x190000		1	1	0	0	1	1		R_StateM_Errors[D26..0]
CHP_ADDR + 0x1a0000		1	1	0	1	0	0		Write/Read_ControlReg D[31..0]
CHP_ADDR + 0x1a8000		1	1	0	1	0	1		Write/Read_TestReg D[31..0]
CHP_ADDR + 0x1a0000		1	1	0	1	1	0		Write_CLK_Reg D[8..0]
CHP_ADDR + 0x1a8000		1	1	0	1	1	1		Write_GAIN_Reg D[3..0]
BROADCAST or CHP_ADDR + 0x1c0000		1	1	1	0	0	0		Write_ModeReg D[31..0]
BROADCAST or CHP_ADDR + 0x1c8000		1	1	1	0	0	1		Write_ResetPuls D[31..0]
CHP_ADDR + 0x1d0000		1	1	1	0	1	0		AutoBaselEn[D24..16] ValueD [9..0]
CHP_ADDR + 0x1d0000		1	1	1	0	1	0		Read_CorrVal_ch# 3 2 1 [D29..0]
CHP_ADDR + 0x1d8000		1	1	1	0	1	1		Read_CorrVal_ch# 6 5 4 [D29..0]
CHP_ADDR + 0x1e0000		1	1	1	1	0	0		Read_CorrVal_ch# 9 8 7 [D29..0]
CHP_ADDR + 0x1f0000		1	1	1	1	1	0		ReadFirmwareVersion

NORTH_CENTERV2 , SOUTH_CENTERV2 LocalBus Addressmap:

		A20	A19	A18	A17	A16	A15	A14	
CHP_ADDR + 0x20000	Channel#1	0	0	0	1	0	0	0	Number of estimated ROCs D[4..0]
CHP_ADDR + 0x28000	Channel#1	0	0	0	1	0	1	0	UltraBlack Threshold D[29..0]
CHP_ADDR + 0x30000	Channel#1	0	0	0	1	1	0	0	Threshold_012 D[29..0]
CHP_ADDR + 0x34000	Channel#1	0	0	0	1	1	0	1	Threshold_34 D[19..0]
CHP_ADDR + 0x38000	Channel#1	0	0	0	1	1	1	0	READ FIFO1 D[31..0]
CHP_ADDR + 0x40000	Channel#2	0	0	1	0	0	0	0	Number of estimated ROCs D[4..0]
CHP_ADDR + 0x48000	Channel#2	0	0	1	0	0	1	0	UltraBlack Threshold D[29..0]
CHP_ADDR + 0x50000	Channel#2	0	0	1	0	1	0	0	Threshold_012 D[29..0]
CHP_ADDR + 0x54000	Channel#2	0	0	1	0	1	0	1	Threshold_34 D[19..0]
CHP_ADDR + 0x58000	Channel#2	0	0	1	0	1	1	0	READ FIFO1 D[31..0]
CHP_ADDR + 0x60000	Channel#3	0	0	1	1	0	0	0	Number of estimated ROCs D[4..0]
CHP_ADDR + 0x68000	Channel#3	0	0	1	1	0	1	0	UltraBlack Threshold D[29..0]
CHP_ADDR + 0x70000	Channel#3	0	0	1	1	1	0	0	Threshold_012 D[29..0]
CHP_ADDR + 0x74000	Channel#3	0	0	1	1	1	0	1	Threshold_34 D[19..0]
CHP_ADDR + 0x78000	Channel#3	0	0	1	1	1	1	0	READ FIFO1 D[31..0]
CHP_ADDR + 0x80000	Channel#4	0	1	0	0	0	0	0	Number of estimated ROCs D[4..0]
CHP_ADDR + 0x88000	Channel#4	0	1	0	0	0	1	0	UltraBlack Threshold D[29..0]
CHP_ADDR + 0x90000	Channel#4	0	1	0	0	1	0	0	Threshold_012 D[29..0]
CHP_ADDR + 0x94000	Channel#4	0	1	0	0	1	0	1	Threshold_34 D[19..0]
CHP_ADDR + 0x98000	Channel#4	0	1	0	0	1	1	0	READ FIFO1 D[31..0]
CHP_ADDR + 0xa0000	Channel#5	0	1	0	1	0	0	0	Number of estimated ROCs D[4..0]
CHP_ADDR + 0xa8000	Channel#5	0	1	0	1	0	1	0	UltraBlack Threshold D[29..0]
CHP_ADDR + 0xb0000	Channel#5	0	1	0	1	1	0	0	Threshold_012 D[29..0]
CHP_ADDR + 0xb4000	Channel#5	0	1	0	1	1	0	1	Threshold_34 D[19..0]
CHP_ADDR + 0xb8000	Channel#5	0	1	0	1	1	1	0	READ FIFO1 D[31..0]
CHP_ADDR + 0xc0000	Channel#6	0	1	1	0	0	0	0	Number of estimated ROCs D[4..0]
CHP_ADDR + 0xc8000	Channel#6	0	1	1	0	0	1	0	UltraBlack Threshold D[29..0]
CHP_ADDR + 0xd0000	Channel#6	0	1	1	0	1	0	0	Threshold_012 D[29..0]
CHP_ADDR + 0xd4000	Channel#6	0	1	1	0	1	0	1	Threshold_34 D[19..0]
CHP_ADDR + 0xd8000	Channel#6	0	1	1	0	1	1	0	READ FIFO1 D[31..0]
CHP_ADDR + 0xe0000	Channel#7	0	1	1	1	0	0	0	Number of estimated ROCs D[4..0]
CHP_ADDR + 0xe8000	Channel#7	0	1	1	1	0	1	0	UltraBlack Threshold D[29..0]
CHP_ADDR + 0xf0000	Channel#7	0	1	1	1	1	0	0	Threshold_012 D[29..0]
CHP_ADDR + 0xf4000	Channel#7	0	1	1	1	1	0	1	Threshold_34 D[19..0]
CHP_ADDR + 0xf8000	Channel#7	0	1	1	1	1	1	0	READ FIFO1 D[31..0]
CHP_ADDR + 0x100000	Channel#8	1	0	0	0	0	0	0	Number of estimated ROCs D[4..0]
CHP_ADDR + 0x108000	Channel#8	1	0	0	0	0	1	0	UltraBlack Threshold D[29..0]
CHP_ADDR + 0x110000	Channel#8	1	0	0	0	1	0	0	Threshold_012 D[29..0]
CHP_ADDR + 0x114000	Channel#8	1	0	0	0	1	0	1	Threshold_34 D[19..0]
CHP_ADDR + 0x118000	Channel#8	1	0	0	0	1	1	0	READ FIFO1 D[31..0]
CHP_ADDR + 0x120000	Channel#9	1	0	0	1	0	0	0	Number of estimated ROCs D[4..0]
CHP_ADDR + 0x128000	Channel#9	1	0	0	1	0	1	0	UltraBlack Threshold D[29..0]
CHP_ADDR + 0x130000	Channel#9	1	0	0	1	1	0	0	Threshold_012 D[29..0]
CHP_ADDR + 0x134000	Channel#9	1	0	0	1	1	0	1	Threshold_34 D[19..0]
CHP_ADDR + 0x138000	Channel#9	1	0	0	1	1	1	0	READ FIFO1 D[31..0]
CHP_ADDR + 0x140000		1	0	1	0	0	0	0	READ_ERROR_FIFOup D[31..0]
CHP_ADDR + 0x148000		1	0	1	0	0	1	0	READ_TEMP_FIFOup D[31..0]
CHP_ADDR + 0x150000		1	0	1	0	1	0	0	READ_SPY-FIFO2up D[31..0]
CHP_ADDR + 0x158000		1	0	1	0	1	1	0	
CHP_ADDR + 0x160000		1	0	1	1	0	0	0	READ_ERROR_FIFOdown D[31..0]
CHP_ADDR + 0x168000		1	0	1	1	0	1	0	READ_TEMP_FIFOdown D[31..0]
CHP_ADDR + 0x170000		1	0	1	1	1	0	0	READ_SPY-FIFO2down D[31..0]
CHP_ADDR + 0x178000		1	0	1	1	1	1	0	
CHP_ADDR + 0x180000		1	1	0	0	0	0	0	
CHP_ADDR + 0x188000		1	1	0	0	0	0	1	
CHP_ADDR + 0x190000		1	1	0	0	1	0	0	
CHP_ADDR + 0x1a0000		1	1	0	1	0	0	0	Write/Read ControlReg D[31..0]
CHP_ADDR + 0x1a8000		1	1	0	1	0	1	0	Write/Read TestReg D[31..0]
CHP_ADDR + 0x1a0000		1	1	0	1	1	0	0	Write CLK_Reg D[8..0]
CHP_ADDR + 0x1a8000		1	1	0	1	1	1	0	Write GAIN_Reg D[3..0]
BROADCAST or CHP_ADDR + 0x1c0000		1	1	1	0	0	0	0	Write ModeReg D[31..0]
BROADCAST or CHP_ADDR + 0x1c8000		1	1	1	0	0	1	0	Write ResetPuls D[31..0]
CHP_ADDR + 0x1d0000		1	1	1	0	1	0	0	AutoBaselEn[D24..16] ValueD [9..0]
CHP_ADDR + 0x1d0000		1	1	1	0	1	0	0	Read CorrVal ch# 3 2 1 [D29..0]
CHP_ADDR + 0x1d8000		1	1	1	0	1	1	0	Read CorrVal ch# 6 5 4 [D29..0]
CHP_ADDR + 0x1e0000		1	1	1	1	0	0	0	Read CorrVal ch# 9 8 7 [D29..0]
CHP_ADDR + 0x1f0000		1	1	1	1	1	0	0	ReadFirmwareVersion

SOUTH_V2 LocalBus Addressmap:

		A20	A19	A18	A17	A16	A15	A14	
CHP_ADDR + 0x20000	Channel#1	0	0	0	1	0	0	0	Number of estimated ROCs D[4..0]
CHP_ADDR + 0x28000	Channel#1	0	0	0	1	0	1	0	UltraBlack Threshold D[29..0]
CHP_ADDR + 0x30000	Channel#1	0	0	0	1	1	0	0	Threshold_012 D[29..0]
CHP_ADDR + 0x34000	Channel#1	0	0	0	1	1	0	1	Threshold_34 D[19..0]
CHP_ADDR + 0x38000	Channel#1	0	0	0	1	1	1	0	READ FIFO1 D[31..0]
CHP_ADDR + 0x40000	Channel#2	0	0	1	0	0	0	0	Number of estimated ROCs D[4..0]
CHP_ADDR + 0x48000	Channel#2	0	0	1	0	0	1	0	UltraBlack Threshold D[29..0]
CHP_ADDR + 0x50000	Channel#2	0	0	1	0	1	0	0	Threshold_012 D[29..0]
CHP_ADDR + 0x54000	Channel#2	0	0	1	0	1	0	1	Threshold_34 D[19..0]
CHP_ADDR + 0x58000	Channel#2	0	0	1	0	1	1	0	READ FIFO1 D[31..0]
CHP_ADDR + 0x60000	Channel#3	0	0	1	1	0	0	0	Number of estimated ROCs D[4..0]
CHP_ADDR + 0x68000	Channel#3	0	0	1	1	0	1	0	UltraBlack Threshold D[29..0]
CHP_ADDR + 0x70000	Channel#3	0	0	1	1	1	0	0	Threshold_012 D[29..0]
CHP_ADDR + 0x74000	Channel#3	0	0	1	1	1	0	1	Threshold_34 D[19..0]
CHP_ADDR + 0x78000	Channel#3	0	0	1	1	1	1	0	READ FIFO1 D[31..0]
CHP_ADDR + 0x80000	Channel#4	0	1	0	0	0	0	0	Number of estimated ROCs D[4..0]
CHP_ADDR + 0x88000	Channel#4	0	1	0	0	0	1	0	UltraBlack Threshold D[29..0]
CHP_ADDR + 0x90000	Channel#4	0	1	0	0	1	0	0	Threshold_012 D[29..0]
CHP_ADDR + 0x94000	Channel#4	0	1	0	0	1	0	1	Threshold_34 D[19..0]
CHP_ADDR + 0x98000	Channel#4	0	1	0	0	1	1	0	READ FIFO1 D[31..0]
CHP_ADDR + 0xa0000	Channel#5	0	1	0	1	0	0	0	Number of estimated ROCs D[4..0]
CHP_ADDR + 0xa8000	Channel#5	0	1	0	1	0	1	0	UltraBlack Threshold D[29..0]
CHP_ADDR + 0xb0000	Channel#5	0	1	0	1	1	0	0	Threshold_012 D[29..0]
CHP_ADDR + 0xb4000	Channel#5	0	1	0	1	1	0	1	Threshold_34 D[19..0]
CHP_ADDR + 0xb8000	Channel#5	0	1	0	1	1	1	0	READ FIFO1 D[31..0]
CHP_ADDR + 0xc0000	Channel#6	0	1	1	0	0	0	0	Number of estimated ROCs D[4..0]
CHP_ADDR + 0xc8000	Channel#6	0	1	1	0	0	1	0	UltraBlack Threshold D[29..0]
CHP_ADDR + 0xd0000	Channel#6	0	1	1	0	1	0	0	Threshold_012 D[29..0]
CHP_ADDR + 0xd4000	Channel#6	0	1	1	0	1	0	1	Threshold_34 D[19..0]
CHP_ADDR + 0xd8000	Channel#6	0	1	1	0	1	1	0	READ FIFO1 D[31..0]
CHP_ADDR + 0xe0000	Channel#7	0	1	1	1	0	0	0	Number of estimated ROCs D[4..0]
CHP_ADDR + 0xe8000	Channel#7	0	1	1	1	0	1	0	UltraBlack Threshold D[29..0]
CHP_ADDR + 0xf0000	Channel#7	0	1	1	1	1	0	0	Threshold_012 D[29..0]
CHP_ADDR + 0xf4000	Channel#7	0	1	1	1	1	0	1	Threshold_34 D[19..0]
CHP_ADDR + 0xf8000	Channel#7	0	1	1	1	1	1	0	READ FIFO1 D[31..0]
CHP_ADDR + 0x100000	Channel#8	1	0	0	0	0	0	0	Number of estimated ROCs D[4..0]
CHP_ADDR + 0x108000	Channel#8	1	0	0	0	0	1	0	UltraBlack Threshold D[29..0]
CHP_ADDR + 0x110000	Channel#8	1	0	0	0	1	0	0	Threshold_012 D[29..0]
CHP_ADDR + 0x114000	Channel#8	1	0	0	0	1	0	1	Threshold_34 D[19..0]
CHP_ADDR + 0x118000	Channel#8	1	0	0	0	1	1	0	READ FIFO1 D[31..0]
CHP_ADDR + 0x120000	Channel#9	1	0	0	1	0	0	0	Number of estimated ROCs D[4..0]
CHP_ADDR + 0x128000	Channel#9	1	0	0	1	0	1	0	UltraBlack Threshold D[29..0]
CHP_ADDR + 0x130000	Channel#9	1	0	0	1	1	0	0	Threshold_012 D[29..0]
CHP_ADDR + 0x134000	Channel#9	1	0	0	1	1	0	1	Threshold_34 D[19..0]
CHP_ADDR + 0x138000	Channel#9	1	0	0	1	1	1	0	READ FIFO1 D[31..0]
CHP_ADDR + 0x140000		1	0	1	0	0	0		READ_ERROR_FIFOup D[31..0]
CHP_ADDR + 0x148000		1	0	1	0	0	1		READ_TEMP_FIFOup D[31..0]
CHP_ADDR + 0x150000		1	0	1	0	1	0		READ_SPY-FIFO2up D[31..0]
CHP_ADDR + 0x158000		1	0	1	0	1	1		READ_SPY-I-up D[31..0]
CHP_ADDR + 0x160000		1	0	1	1	0	0		READ_ERROR_FIFOdown D[31..0]
CHP_ADDR + 0x168000		1	0	1	1	0	1		READ_TEMP_FIFOdown D[31..0]
CHP_ADDR + 0x170000		1	0	1	1	1	0		READ_SPY-FIFO2down D[31..0]
CHP_ADDR + 0x178000		1	0	1	1	1	1		READ_SPY-I-down D[31..0]
CHP_ADDR + 0x180000		1	1	0	0	0	0		OPTOPAR RECEIVER1 D[7..0]
CHP_ADDR + 0x188000		1	1	0	0	0	1		OPTOPAR RECEIVER2 D[7..0]
CHP_ADDR + 0x190000		1	1	0	0	1	0		OPTOPAR RECEIVER3 D[7..0]
CHP_ADDR + 0x1a0000		1	1	0	1	0	0		Write/Read ControlReg D[31..0]
CHP_ADDR + 0x1a8000		1	1	0	1	0	1		Write/Read TestReg D[31..0]
CHP_ADDR + 0x1a0000		1	1	0	1	1	0		Write CLK_Reg D[8..0]
CHP_ADDR + 0x1a8000		1	1	0	1	1	1		Write GAIN_Reg D[3..0]
BROADCAST or CHP_ADDR + 0x1c0000		1	1	1	0	0	0		Write ModeReg D[31..0]
BROADCAST or CHP_ADDR + 0x1c8000		1	1	1	0	0	1		Write ResetPuls D[31..0]
CHP_ADDR + 0x1d0000		1	1	1	0	1	0		AutoBaselEn[D24..16] ValueD [9..0]
CHP_ADDR + 0x1d0000		1	1	1	0	1	0		Read CorrVal ch# 3 2 1 [D29..0]
CHP_ADDR + 0x1d8000		1	1	1	0	1	1		Read CorrVal ch# 6 5 4 [D29..0]
CHP_ADDR + 0x1e0000		1	1	1	1	0	0		Read CorrVal ch# 9 8 7 [D29..0]
CHP_ADDR + 0x1f0000		1	1	1	1	1	0		ReadFirmwareVersion

ERROR FIFOs:

Data path from FIFO I to FIFO II :

The EnableBit decides if the data is a normal Pixeldata or if the data is type of error data or LastDac(temp) data.
We have eight Error FIFOs (two per FrontAltera) each responsible for four or five input channels !

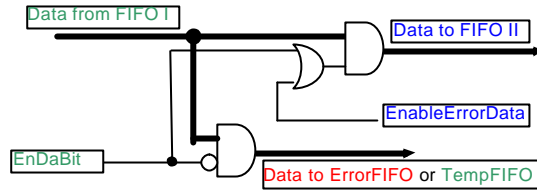

Error Coding and Temp FIFO:

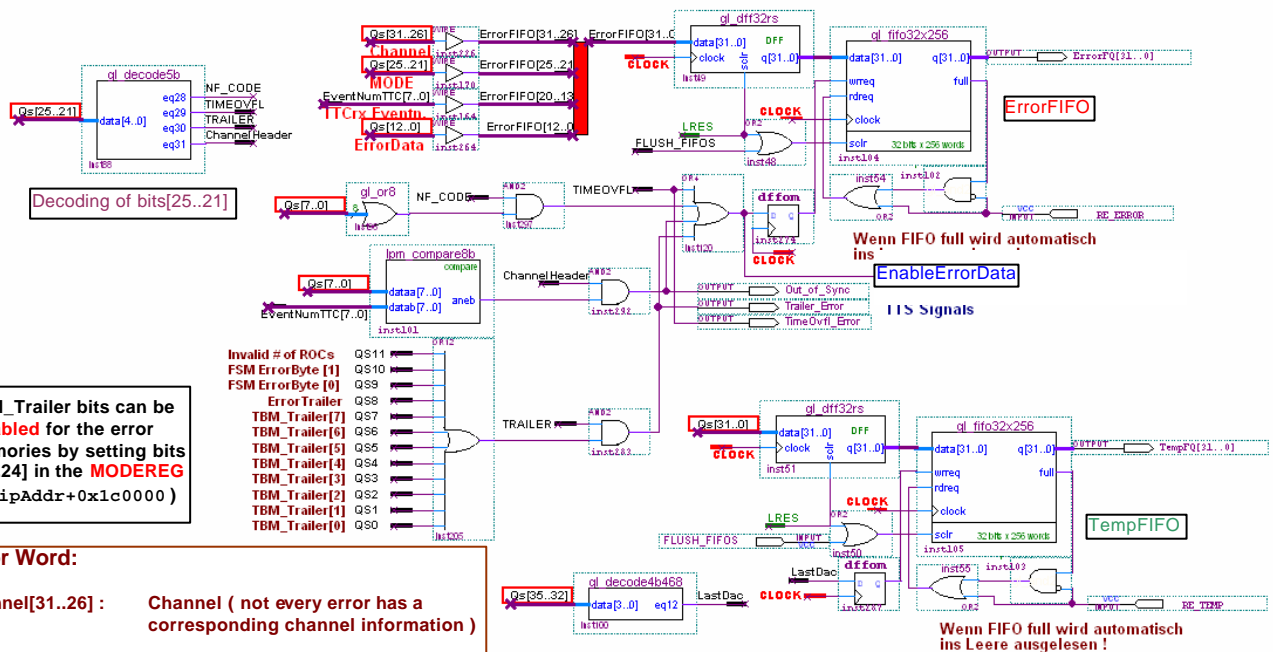

TBM_Trailer bits can be disabled for the error memories by setting bits [31..24] in the MODEREG (ChipAddr+0x1c0000)

Error Word:
Channel[31..26] : Channel (not every error has a corresponding channel information)
Code[25..21] : ErrorCode: 0x1f EventnumberError, 0x1e Trailer Error, 0x1d TimeOut, 0x1c NF MEM, 0x1b Dummy
TTCrxEvent#[20..13]: 8 LSBs of TTCrx Eventnumber
ErrorData[12..0]: ErrorType dependend !

When FIFOs are full they will be automatically exhausted !

ERROR FIFO BIT MEANINGS:

D31	D30	D29	D28	D27	D26	D25	D24	D23	D22	D21	D20	D19	D18	D17	D16	D15	D14	D13	D12	D11	D10	D9	D8	D7	D6	D5	D4	D3	D2	D1	D0
-----	-----	-----	-----	-----	-----	-----	-----	-----	-----	-----	-----	-----	-----	-----	-----	-----	-----	-----	-----	-----	-----	----	----	----	----	----	----	----	----	----	----

Channel#										EVnrERROR								8 LSBs ofTTCrx Eventnumber								Data word = Channel event #												
C5	C4	C3	C2	C1	C0	1	1	1	1	1	E7	E6	E5	E4	E3	E2	E1	E0	X	X	X	X	X	X	X	X	X	X	X	X	E7	E6	E5	E4	E3	E2	E1	E0

TIMEOUT										8 LSBs ofTTCrx Eventnumber								Data word (Bit = channel with error)																	
X	X	X	X	X	X	X	X	X	X	1	1	1	0	1	E7	E6	E5	E4	E3	E2	E1	E0	X	X	B[2]	B[1]	B[0]	X	X	X	CH5	CH4	CH3	CH2	CH1

BlockNr: (Block of 4 or 5 Input Channels)

Channel#										TrailerERROR								8 LSBs ofTTCrx Eventnumber								8bit TBM trailer							
C5	C4	C3	C2	C1	C0	1	1	1	1	0	E7	E6	E5	E4	E3	E2	E1	E0	X	R#	S[1]	S[0]	OVF	T7	T6	T5	T4	T3	T2	T1	T0		

invalid # of ROCs FSM Errors data stream to long

NearlyFULL										8 LSBs ofTTCrx Eventnumber								Data word (Bit = channel FIFO1NF)																						
X	X	X	X	X	X	1	1	1	0	0	E7	E6	E5	E4	E3	E2	E1	E0	X	X	X	X	X	X	X	X	X	X	X	X	X	X	L1A	NF1I	X	NF6	NFd	NFc	NFb	NFa

Event#FIFO NF FIFO II NF

Nearly FULL has only limited value of information ! NF error is only stored when FIFO II is emptying and this is not the time when NF occurs !!!!

Error words in normal data stream:

ROC numbers 26 to 31 are reserved for error type or special word recognition.

- .) Error words are only transmitted when error information is found.
- .) Dummy data (**27**)have to be included when there are too less data!
- .) When combining two 32bit data streams, gaps are marked with **26**

ROC# **1 ..24** Gap **26** DummyData **27** NearlyFull **28** Timeout **29** TrailerErr **30** EvnrErr **31**

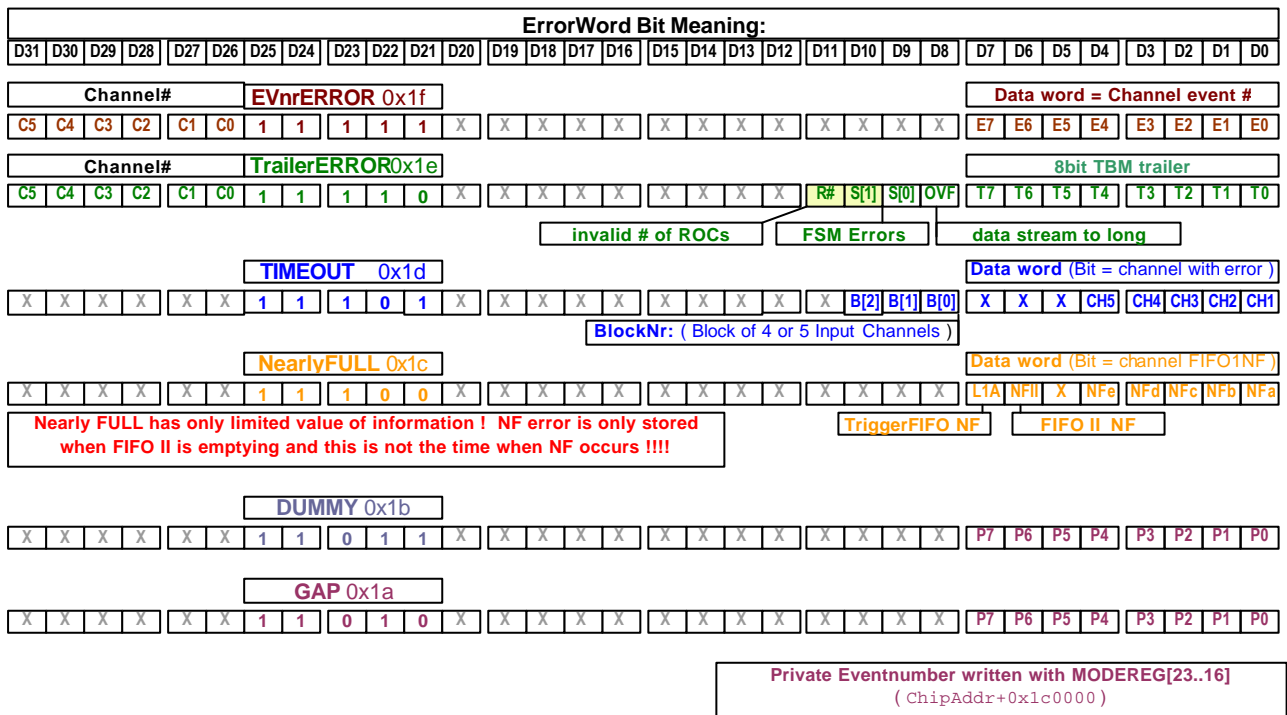

These data are transferred via the Center Chip to the S-link.

Only the EVnrERROR information generates a TTS event under following conditions:

two consecutive event blocks have to have at least 64 Out of Sync Errors to generate a TTS OUTofSYNC signal !!!!!

or consecutive event blocks have 64 Out of Sync Errors ! (**a healthy event in between will clear the Out of Sync Error Counter**)

FIFO DEPTHS:

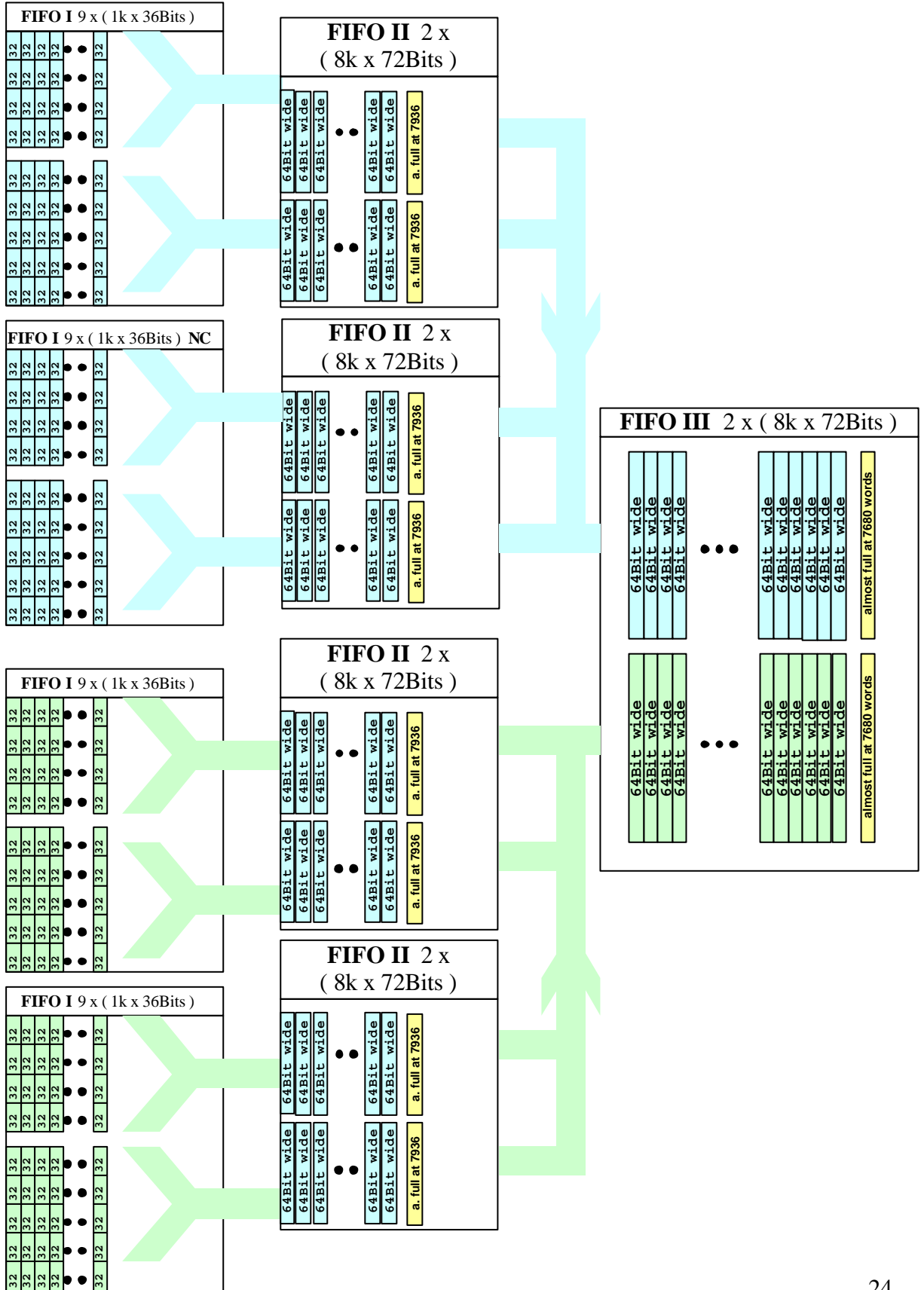

“ CENTER “ FPGA

Data Path Block Diagram :

Data from NORTH and NORTHCENTER

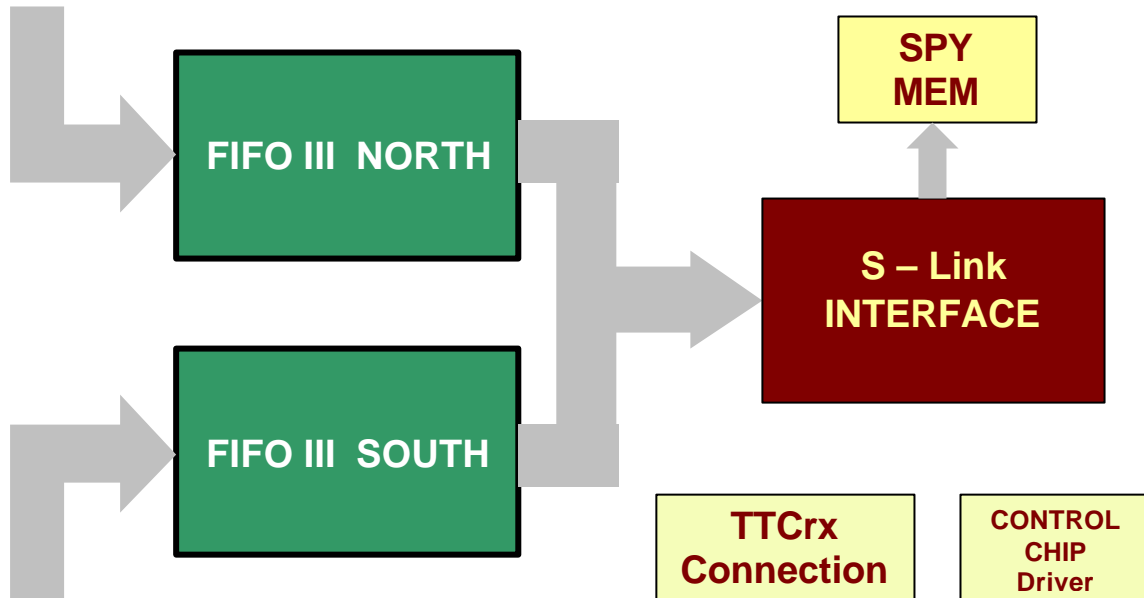

Data from SOUTH and SOUTHTHCENTER

CENTER LOCAL BUS ADDRESSES:

	A20	A19	A18	A17	A16	A15	
CHP_ADDR + 0x20000	0	0	0	1	0	0	CLEAR_HIST (needs 12.8us)
CHP_ADDR + 0x28000	0	0	0	1	0	1	EnHistogramming D[0]
CHP_ADDR + 0x30000	0	0	0	1	1	0	TRIPPLE select UP D[2..0]
CHP_ADDR + 0x38000	0	0	0	1	1	1	TRIPPLE select DOWN D[2..0]
CHP_ADDR + 0x40000	0	0	1	0	0	0	ROC_READ_UP A[6..2]
CHP_ADDR + 0x48000	0	0	1	0	0	1	ROC_READ_DOWN A[6..2]
CHP_ADDR + 0x60000	0	0	1	1	0	0	READ TTS-FIFO D[31..0]
CHP_ADDR + 0xe0000	0	1	1	1	0	0	Write SourceID D[5..0]
CHP_ADDR + 0xf0000	0	1	1	1	1	0	WR TTS_Linet. D[31],[3..0]
CHP_ADDR + 0x140000	1	0	1	0	0	0	READ SPY-FIFOup D[31..0]
CHP_ADDR + 0x160000	1	0	1	1	0	0	READ SPY-FIFOdown D[31..0]
CHP_ADDR + 0x180000	1	1	0	0	0	0	WR Event#, D[8]=1 + D[7..0]
CHP_ADDR + 0x180000	1	1	0	0	0	0	StartTrp D[9]=1
CHP_ADDR + 0x188000	1	1	0	0	0	1	RD BUNCH Counter D[31..0]
CHP_ADDR + 0x190000	1	1	0	0	1	0	RD EVENT Counter D[31..0]
CHP_ADDR + 0x198000	1	1	0	0	1	1	RD LIA Counter D[31..0]
CHP_ADDR + 0x1a0000	1	1	0	1	0	0	W/R ControlReg D[31..0]
CHP_ADDR + 0x1a8000	1	1	0	1	0	1	W/R TestReg D[31..0]
BROADCAST or CHP_ADDR + 0x1c0000	1	1	1	0	0	0	WRITE ModeReg D[31..0]
BROADCAST or CHP_ADDR + 0x1c8000	1	1	1	0	0	1	WRITE ResetPuls D[31..0]
CHP_ADDR + 0x1f0000	1	1	1	1	1	0	ReadFirmwareVersion

Control and ModeReg Meaning:

```

CtrlReg[0]=0/1 ==> Disable/Enable Transparent Mode
CtrlReg[1]=0/1 ==> TranspGateStart by L1A / TranspGateStart by VME or EFT(OPTO Module)
CtrlReg[2]=0/1 ==> Disable/Enable DAC Data for Transparent Mode
CtrlReg[3]=0/1 ==> TTC Event# / VME Event#
CtrlReg[4]=0/1 ==> Disable/Enable L1A from TTCrx
CtrlReg[5]=0/1 ==> Disable/Enable EFT Signal from OPTO Module

```

```

CtrlReg[16]=0/1 ==> TTSReady dis/en
CtrlReg[17]=0/1 ==> TTSError dis/en
CtrlReg[18]=0/1 ==> OUTofSYN dis/en

```

```

ModeReg[0]=1 ==> S-Link disable
ModeReg[1]=1 ==> Write Disable SPY MEM
ModeReg[2]=1 ==> URESET ( S-Link Reset )
ModeReg[3]=1 ==> Ignore Slink LFF

```

```

ModeReg[31]=1 ==> Select Slink Test Pattern

```

Special Test Pattern DAC Mode:

Note: A special mode should be used when random triggers are anticipated and the testDAC test Pattern is desired. In this case set:

```

CtrlReg[2]=0 in the CENTER Control Register (Disables normal DAC data mode)

```

And

```

ModeReg[0]=1 in the NORTH Mode Register (Enables Special DAC data mode)

```

COLUMN COUNTER:

The ColumnCounter implemented in the CENTER CHIP needs 36 x 8k Bits of memory and runs with 80Mhz to handle both coordinates in one 64 bit wide word.

BLOCK SCHEMATICS:

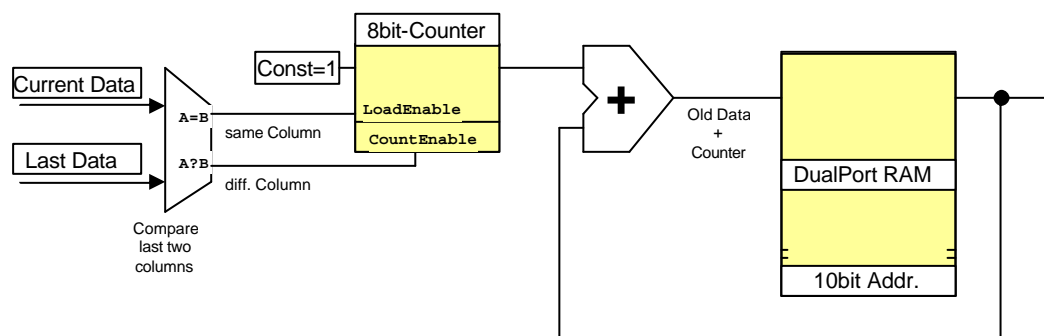

Until now there is no stop mechanism implemented to prevent the ColumnCounter from overrunning.

The readout scheme is as follows:

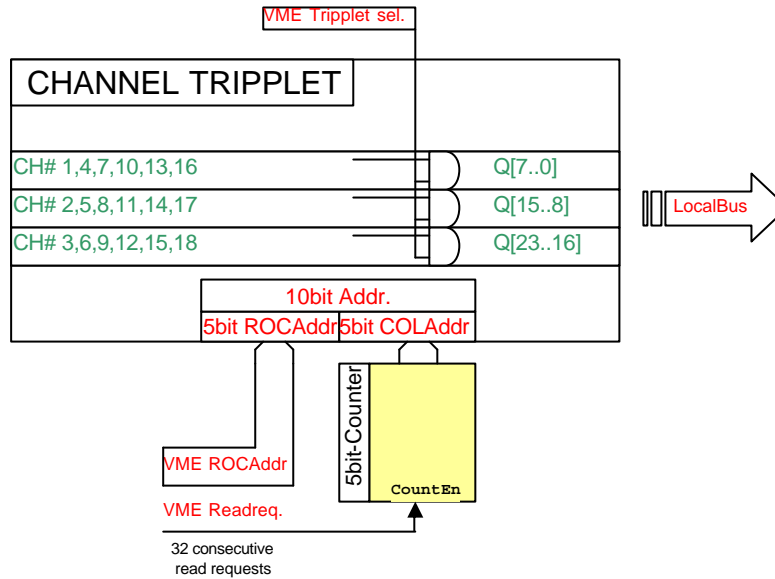

One must do 32 consecutive read requests on a ROC address to properly position the 5-bit column address counter to 0 so that the DOUBLE COLUMN address for the next ROC begins at DOUBLE COLUMN address 0!

`CLEAR_HIST` (CHP_ADDR+0x20000)

Resets the Column_Hist Dual Port Memory. In fact each memory address is set to zero. (1024 x 12.5ns = 12.8µs)

`EnHistogramming` (CHP_ADDR+0x28000) D[0]

Until now the histogramming is done as long as this bit is set, regardless of any possible counter overflows !

TTS System:

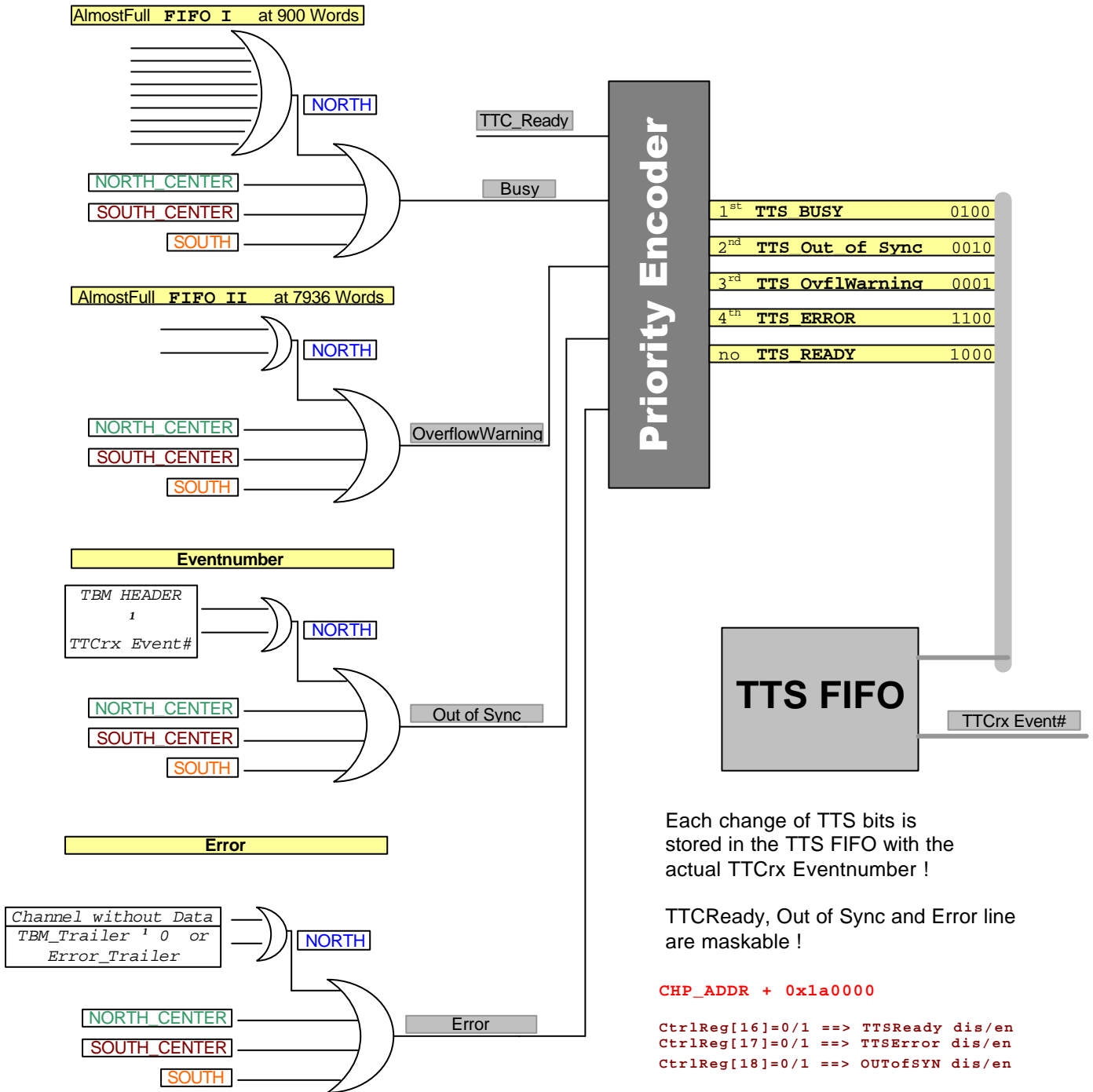

TTS FIFO read address: **LAD_C + 0x60000**

For connectivity tests a register is foreseen to set all TTS lines by VME command:

LAD_C+0xe0000 D[31] enable TTS line test

 D[3] ready pins 6,3

 D[2] busy pins 2,1

 D[1] out of synch pins 8,7

 D[0] overflow warning pins 4,5

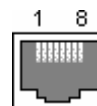

Slink Header and Trailer words:

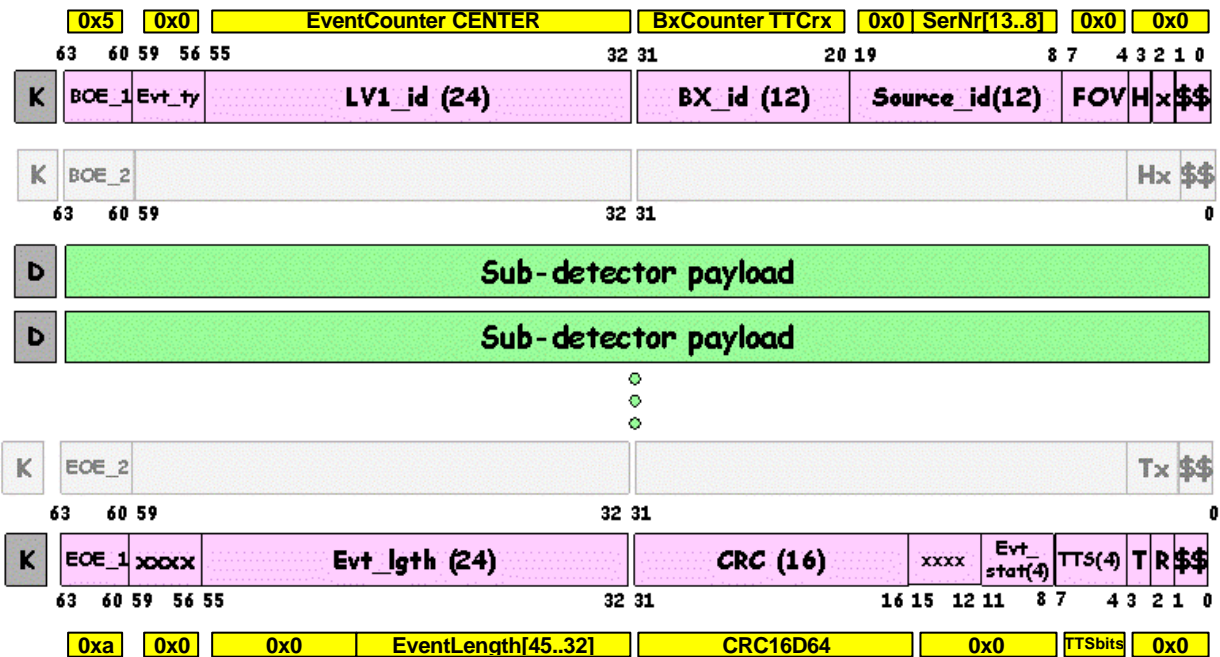

EventCounter CENTER

24bit event counter incremented by L1Accept.

Reset possibilities: LocalBus Reset **or** B-channel Command BRCST[5..0] = 0x2 (= reset EventCounter) **or** B-channel Command BRCST[5..0] = 0x14 (= FullReset)

BxCounter TTCrx

BxCounter information from TTCrx chip.

SerNr[13..8]

FED Serial Number set by dipswitch SW5. Switch ON(OFF) Means bit = 0(1). Switch #1 (or closest to front of board) Corresponds to bit position 0 of bits 0-5 in the Serial Number Register.

This Serial Number can be read with: FedBase+0xa00000 (D[5..0]) and has to be written to the CENTER Chip register LAD_C+0xe000 at module initialisation time.

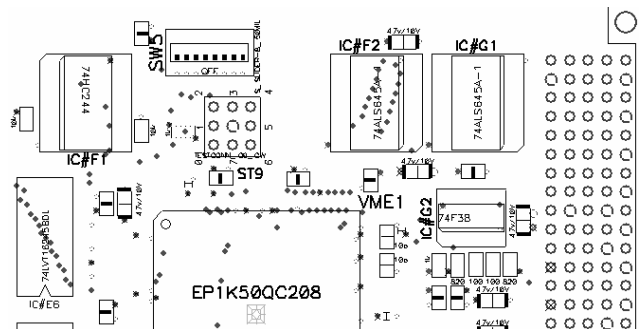

EventLength[45..32]

Our EvenLengthCounter is only 14 bit wide ! (two times 8192 words FIFO III depth)

Small events:

The next picture shows a Slink data dump for a small event (every third channel has one hit).

The gray marked fillwords originate from our ambition to avoid too short blocks in our data path.

A fillword can be identified by:

CH = 0 ; ROC = 0x1b ; DC = 0 ; PXL = 0 ; PH = private event type

On the way from FIFO I to FIFO II short blocks are filled up until they have at least six words.

Small Event Test:

	50000008	87100700	BOE_1	LV1_ID	BX_I	Source_ID
[000]						
[001]	4 7 9 56 af	1 7 9 56 af				
[002]	0 1b 0 0 1	0 1b 0 0 1	N up			six 32 bit words!
[003]	0 1b 0 0 1	0 1b 0 0 1				
[004]	0 1b 0 0 1	7 7 9 56 b0				
[005]	0 1b 0 0 1	0 1b 0 0 1	N down			
[006]	0 1b 0 0 1	0 1b 0 0 1				
[007]	13 7 9 56 ae	10 7 9 56 af				
[008]	0 1b 0 0 1	0 1b 0 0 1	NC up			Fillwords (PrivEvTyp=1)
[009]	0 1b 0 0 1	0 1b 0 0 1				
[010]	0 1b 0 0 1	16 7 9 56 ae				
[011]	0 1b 0 0 1	0 1b 0 0 1	NC			
[012]	0 1b 0 0 1	0 1b 0 0 1				
[013]	22 7 9 56 ae	19 7 9 56 b1				
[014]	0 1b 0 0 1	0 1b 0 0 1	SC up			
[015]	0 1b 0 0 1	0 1b 0 0 1				
[016]	0 1b 0 0 1	25 7 9 56 b0				
[017]	0 1b 0 0 1	0 1b 0 0 1	SC down			
[018]	0 1b 0 0 1	0 1b 0 0 1				
[019]	31 7 9 56 b0	28 7 9 56 af				
[020]	0 1b 0 0 1	0 1b 0 0 1	S up			
[021]	0 1b 0 0 1	0 1b 0 0 1				
[022]	0 1b 0 0 1	34 7 9 56 ae				
[023]	0 1b 0 0 1	0 1b 0 0 1	S down			
[024]	0 1b 0 0 1	0 1b 0 0 1				
[025]	a000001a	0f510000	EOE_1	EvtLength	CRC16	

received : 6 -> data_size = 2

Slink Test Pattern:

Setting ModeReg[31] (`LAD_C + 0x1c0000`) sends the following test pattern over the Slink cable:

```

0x 50## EV## 0000 0000
0x aaaa aaaa aaaa aaaa
0x 5555 5555 5555 5555
0x 0000 0000 0000 0000
0x ffff ffff ffff ffff
0x 0000 0000 0000 0000
0x ffff ffff ffff ffff
0x 0f0f 0f0f 0f0f 0f0f
0x f0f0 f0f0 f0f0 f0f0
0x cccc cccc cccc cccc
0x 3333 3333 3333 3333
0x ffff ffff 0000 0000
0x 0000 0000 ffff ffff
0x aaaa aaaa aaaa aaaa
0x 5555 5555 5555 5555
0x 0000 0000 0000 0000
0x ffff ffff ffff ffff
0x a000 0012 -CRC 0000

```

Eventnumber starts with one after LocalBus Reset ! Length of Event = 0x12

ALTERA PLL and reset TTCrx:

Phase relationships between PLL output clocks need to be maintained after a loss of lock condition !

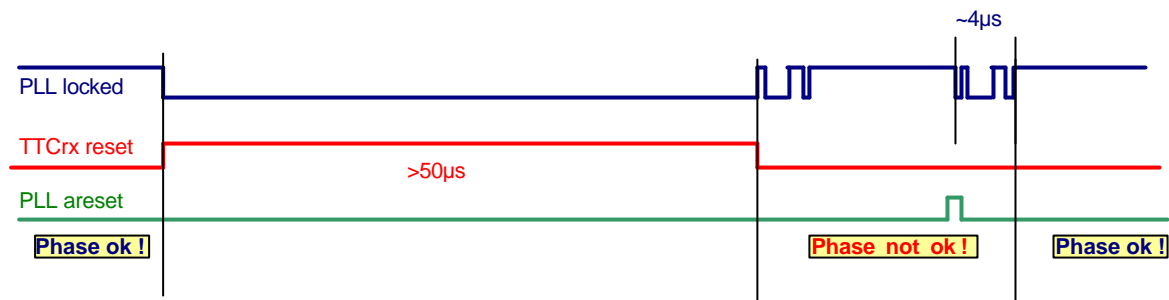

In V4 firmware a PLL areset is done with each LocalBusReset or individually with `CHIPAddr+0x1c8000 D[29]=1`

A LocalBusReset doesn't influence the PLL for the 80MHz clock (Slink) in the Center Chip, a PLL resync can only be done with the individual Reset `0x1c8000 D[29]=1`

A PLL areset is also recommended after power up !

Timeout mechanism:

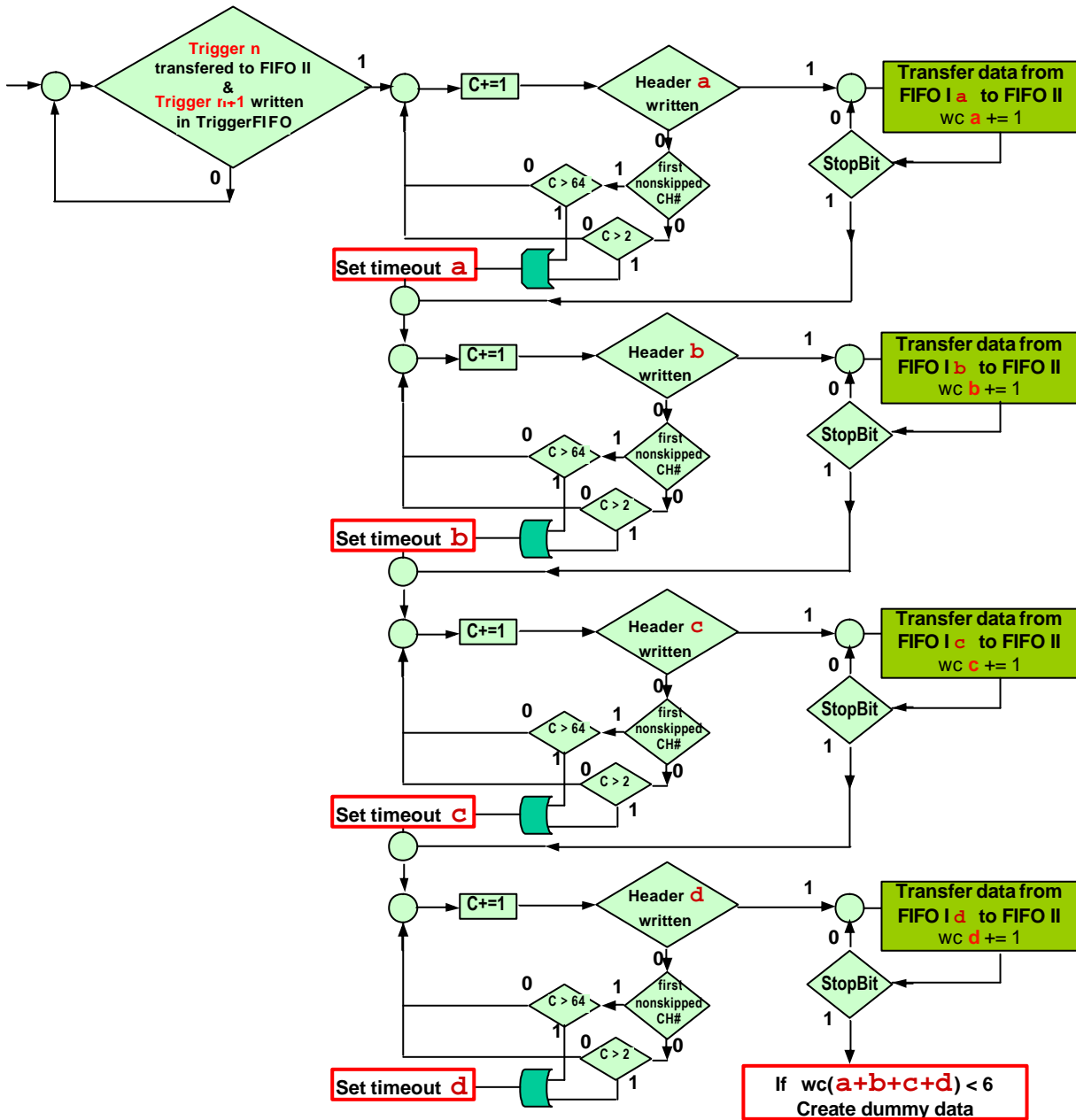

Set timeout means that an error word with error code 0x6 is written in the corresponding error FIFO !

Firmware Versions:

Each **FRONT ALTERA** and the **CENTER ALTERA** has a read only version date register

BaseAddr + ChipAddr + 0x1f0000

The **VME ALTERA** has its version date register at *BaseAddr + 0xa0003c*

day				month				year				year																			
31	30	29	28	27	26	25	24	23	22	21	20	19	18	17	16	15	14	13	12	11	10	09	08	07	06	05	04	03	02	01	00

[hex] coded

(for example: 0x 16 08 14 07 means 22.8.2007)

Fifo Status:

It is possible to check the status of the fifos I, II & III by reading the Control Register.

LAD_C + 0x1a0000

Bit	Meaning
[0]	.. AlmostFull FIFO I North (all 9 Input Channels or - ed)
[1]	.. NearlyFull FIFO II North (or of both FIFO II)
[2]	.. AlmostFull FIFO I NorthCenter
[3]	.. NearlyFull FIFO II NorthCenter
[4]	.. AlmostFull FIFO I SouthCenter
[5]	.. NearlyFull FIFO II SouthCenter
[6]	.. AlmostFull FIFO I South
[7]	.. NearlyFull FIFO II South
[8]	.. AlmostFull FIFO III UP
[9]	.. AlmostFull FIFO III DOWN

It is possible to check whether SpyFifo3 has an entire event in its buffer.

LAD_C + 0x190000

Bit	Meaning
[31]	= 1 (Whole event in SpyFifo3)
[31]	= 0 (No or partial event in SpyFifo3)

Caution: To ensure a whole event, the SpyFifo3 loads one event *after* the SpyFifo3 disable is received. One should read the event *after* disable is set. Otherwise another event can try to fill the SpyFifo3 even when the SpyFifo3 disable is received.

TTCrxSwitches:

It is possible to set TTCrx pins Dout[7..0] high or low using SW3 and TTCrx pins SubAddr[7..0] high or low using SW4.

These switches can therefore be used to set an ID and Master Mode for the TTCrx chip.

The bits for the Master Mode should be let in the **lower position**. This means MasterMode[1..0] = 0 (See the TTCrx manual for more Information.)

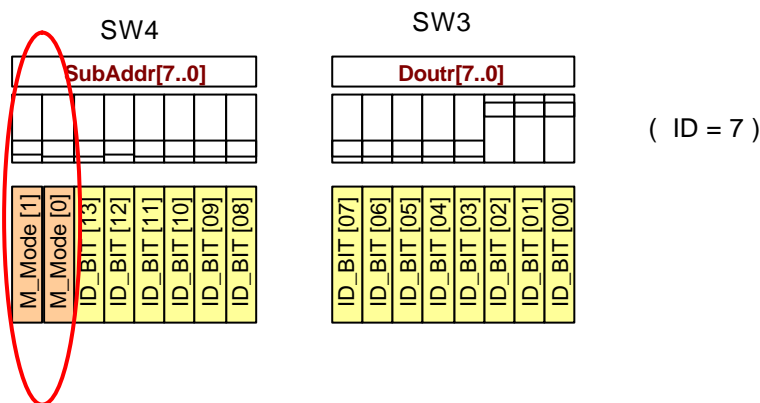

Base Address Switches:

There are 2 rotary switches located below the VME FPGA. These switches provide the VME Base Address (A31-A24) for the board. For example, the Base Address used during the testing of the boards was typically set to 0x1c000000. This looks like

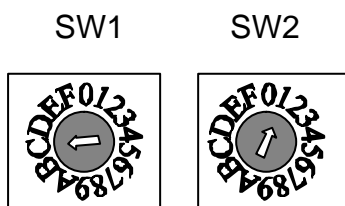

Other Switches/Jumpers:

L1_CK_RDY_EN: Switch to “open”. Signal is used in conjunction with a special test board. (Open in this context means pin 12 of IC # H3 should be pulled “high”.)

VME_64X: Not Implemented. Can be left Closed (Jumpered).

Firmware Programming:

The **FRONT ALTERA FPGA's (N, NC, SC & S)** and the **CENTER ALTERA FPGA's (CENTER & CLOCK)** are re-programmable either using a JTAG programmer, like the USB Blaster, with the proper cable and connector, or through the internal VME interface (mentioned earlier).

One just needs to set switches to indicate which mode (Cable or VME) is to be used.

Note 1: The physical switches for the Front FPGA's are arranged so that the positions look the same without having to refer to the switch label (use caution!).

Note 2: Prior to V4, switches IC4_OE and IC9_OE need to be switched ON(OFF) for VME(CABLE) programming .

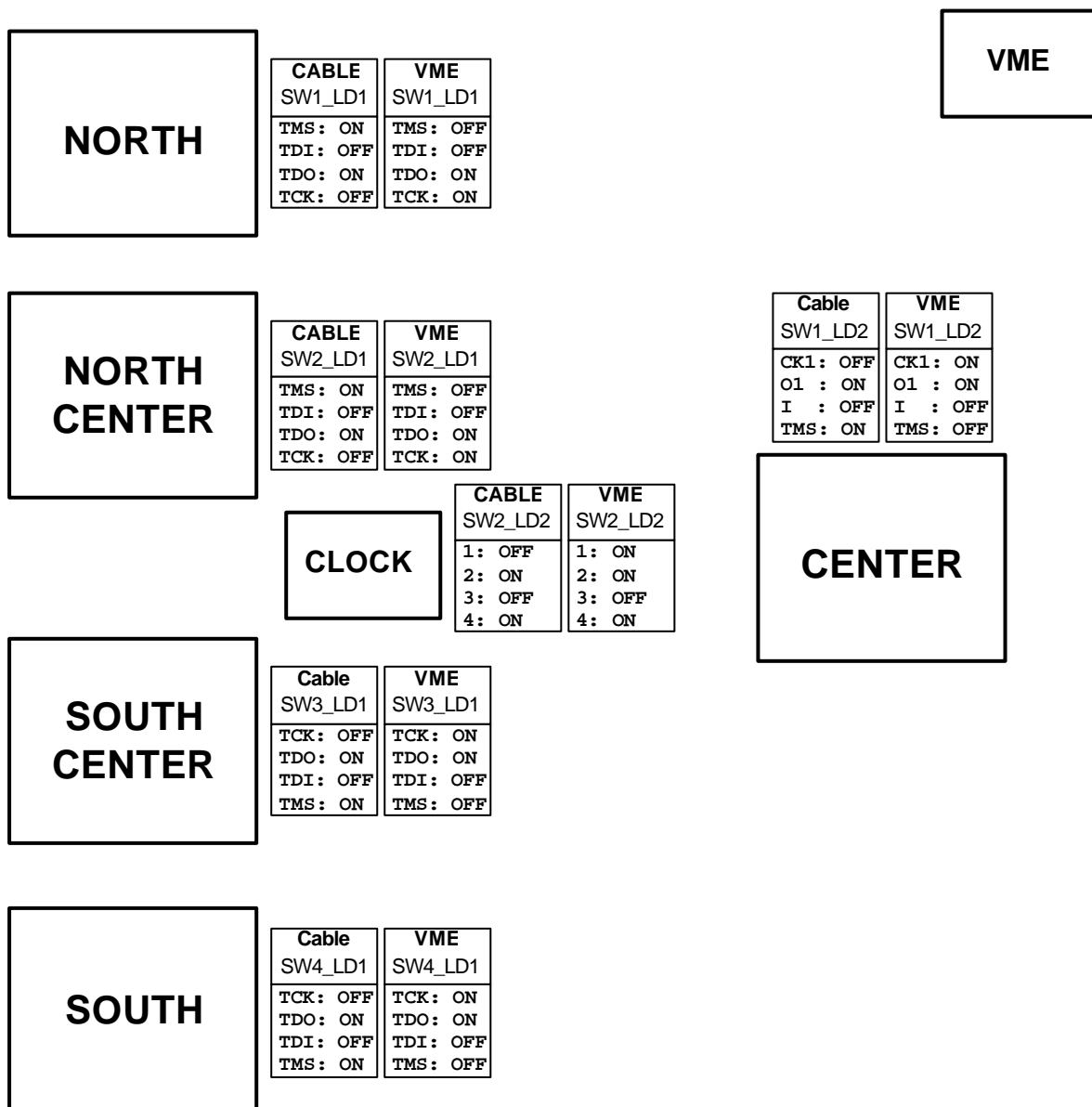

NOTES :

